



# City of El Segundo

September 14, 2020

**ADDENDUM NO. 2**  
to  
THE CONTRACT DOCUMENTS, SPECIFICATIONS AND PLANS  
for  
WATER MAIN IMPROVEMENTS ON INDIANA STREET  
PROJECT NO.: PW 20-04

**ATTENTION BIDDERS:**

The following additions, modifications, and clarifications to the specifications shall be included in, and become a part of, any contract which may be executed for the above project in the City of El Segundo:

- 1. The bid due date and time have been changed to Tuesday, September 22, at 11:00 am**
2. Please see this project's attached Supplement to Addendum 2 for contractor questions and the City's responses to them.
3. Please note the changes to the bid opening procedure listed in the Supplement.

As evidence that the BIDDER has read this Addendum, the BIDDER must acknowledge same in the space provided below and **submit this Addendum with the Bid Proposal**. Failure to provide such acknowledgement shall render the bid as non-responsive and subject to rejection.

Signature: \_\_\_\_\_ Date: \_\_\_\_\_

Print Company Name: \_\_\_\_\_

**CITY OF EL SEGUNDO  
WATER MAIN IMPROVEMENTS ON INDIANA STREET  
PROJECT NO.: PW 20-04**

**ADDENDUM NO. 2 SUPPLEMENT**

**DATE:** September 14, 2020

**TO:** All Prospective Bidders

The following questions have been raised regarding this bid. The response to each question is provided here and made available to all prospective bidders. The information and clarification provided in this Addendum shall be considered as incorporated into the specifications for the above-referenced project. All other portions of Contract Documents and previous Addenda not specifically mentioned in this Addendum remain in force.

**Question 1:** Plans say construct 10” CL350 DIP installed per WT-11, WT-11 shows a 1” Air vac? Or should it read per drawing WT-7, WT-6 (Restrained Length Tables )?

**Answer:** WT-11 was the trench resurfacing standard at the time this was designed (before the City revised the water standards. The following construction notes are changed to reference the current water standards, shown in Appendix 4 of the specifications:

Construction Note 1:  
CONSTRUCT 10-INCH DUCTILE IRON WATER MAIN, PIPE BEDDING, BACKFILL, AND TRENCH RESURFACING PER CITY STANDARD DRAWING NO. ~~WT-11~~ WT-7.

Construction Note 2:  
INSTALL 10-INCH GATE VALVE AND ADJUSTABLE VALVE BOX PER CITY STANDARD DRAWING NO. ~~WT-11~~ WT-10.

Construction Note 4:  
CONSTRUCT 2-INCH WATER CONNECTION PER CITY STANDARD DRAWING NO. ~~WT-2~~ WT-1 AND CONNECT TO EXISTING CUSTOMER SERVICE WITH FITTINGS, REDUCERS, AND COUPLINGS AS REQUIRED. REPAIR/REPLACE EXISTING LANDSCAPE, CONCRETE, AND HARDSCAPE IMPROVEMENTS IN KIND.

Construction Note 6:  
INSTALL 6-INCH GATE VALVE AND ADJUSTABLE VALVE BOX PER CITY STANDARD DRAWING NO. ~~WT-11~~ WT-10.

Construction Note 10:  
INSTALL 4-INCH GATE VALVE AND ADJUSTABLE VALVE BOX PER  
CITY STANDARD DRAWING NO. ~~WT-14~~ WT-10.

Construction Note 3's reference to WT-1 remains the same.

**Question 2:** Is the pipe to be Restrained with Field Lok Gaskets per Table WT-6?

Answer: Yes, pipe joints are to be restrained per standard WT-6.

**Question 3:** There is no bid item for the 8" Gate Valve?

Answer: Include the costs associated with the 8" gate valve on Pine Avenue in Bid Item 14.

## **SEPTEMBER 22, 2020 CHANGES TO THE BID OPENING PROCEDURE:**

City Hall is located at 350 Main Street, El Segundo, CA 90245. At this time it is uncertain which City Hall entry points will be accessible to the public when the building re-opens next week. Given that, please follow the procedure below for next Tuesday's bid opening:

1. Each bidder's representative is required to wear a mask and maintain a 6-foot distance when interacting with City staff and others, and when they are inside the building.
2. Instead of the City Clerk's Office, the bid opening will be held either in the City Hall Council Chambers or in the foyer in front of the Council Chambers. These areas are accessible through the double automatic doors on the west end (Main Street side) of the City Hall Building. The double doors will be unlocked and opened 15 minutes prior to the bid opening.
3. Bidders are more than welcome to submit their bid by the US postal service or other carrier service. However, the bidder is responsible for verifying their bid has been received in the City Clerk's Office prior to the bid opening. The City Hall number is 310-524-2300.
4. Bidders can also choose to submit bids in person. The City Clerk's Office will open the doors 15 minutes before the bid opening and will accept bids at that time. Please plan to be there early enough so that your bid may be received well before 11:00 am, in case there are multiple bidders there to do the same thing.
5. The City Clerk's Office will collect bid packages and record them on a log sheet. Having submitted their bid, bidders will wait outside the double doors in the quad until the bid opening.
6. Bid packages will either be opened in the Council Chambers or in the foyer. Bid amounts will be recorded on the log sheet and the log sheet will be signed by representatives from the City Clerk's Office and the Public Works Department.
7. The Public Works Department will email the bid log sheet to all planholders shortly after the bid opening.

CITY OF EL SEGUNDO APPROVED MATERIALS LIST FOR  
USE ON CONSTRUCTION OF POTABLE WATER FACILITIES

NO.	ITEM	DESCRIPTION	MANUFACTURER/MODEL
1-1	AIR/VACUUM VALVE greater than 2-inch	Epoxy coated/lined. Stainless steel hardware/ PVC	ARI D-060 or ARI D-040
1-2	AIR/VACUUM VALVE ABOVE GRADE ENCLOSURE	Air-Vaccum Valve Assembly. "Valve Box" for below grade components	Pipeline Products VCAS 1830 4", Color shall be Granite
			Pipeline Products VCAS 2436 6-8 inch, Color shall be Granite
1-3	ANGLE METER STOPS 1-inch - Compr. x Swivel Meter Nut, Flare. x Swivel Meter Nut	1" Bronze Angle Meter Stop (Ball Valve) with 90 Degree Lock Wing, Compr.(Flare) x Outlet Swivel Meter Nut	Mueller B-24258 N-3
			Mueller B-24255 N-3
			Jones E-1963 WSG L/S
			Jones E-1964 W L/S
1-4	ANGLE METER STOPS 2-inch - Compr. x Meter Flg, Flare. x Meter Flg	2" Bronze Angle Meter Stop (Ball Valve) with 90 Degree Lock Wing, Compr. x Outlet Meter Flange	Mueller B-24276 N-3
			Mueller B-24286 N-3
			Jones E-1975WSG L/S
			Jones E-1974WSG L/S
1-5	BACKFLOW PREVENTER (R.P.)	Reduced Pressure Principal Type Assemblies; Double Check, Valve Detector Assemblies for Fire Sprinkler Systems	List of Approved Assemblies by USC Foundation for Cross-Connection Control And Hydraulic Institute.
1-6	1" and 2" BALL CORPORATION STOP, MIP x Compression	Bronze Compression x MIP Thread Ball Valve 1" and 2" Full Opening, Ball Corp. and Saddle shall be constructed by same manufacturer.	Mueller B-25028 N
			Jones E-1935SG
1-7	Inline BALL Valves, FIP x FIP	FIP (NPT) Ball Valve	Mueller B-20200-N - 3 (1" - 2")
1-8	Meter Fittings	Fittings required to connect ball valve to various meter sizes, Swivel end, flanged end	Mueller H10890N
			Mueller H1088900N
			Mueller H10129N
1-9	BOLTS AND NUTS	Bolts and nuts shall be 316 Stainless Steel	T316 SS Hex Bolt
			T316 SS Hex Nut
			T316 SS Hex Washers

CITY OF EL SEGUNDO APPROVED MATERIALS LIST FOR  
USE ON CONSTRUCTION OF POTABLE WATER FACILITIES

NO.	ITEM	DESCRIPTION	MANUFACTURER/MODEL
2-1	CASING END SEAL	1/4" Thick Styrene Butadiene Rubber Sheet End Seal. Use 1" Wide Stainless Steel Bands. Zippered End Seals with Stainless, Steel Bands may also be used.	Advanced Products & Sys.
			Cascade
			Calpico
			Pipeline Seal & Insulator
			Powerseal
2-2	CASING SPACER	Stainless Steel Casing Spacer, Center Restrained, Position Type with PVC Liner and Non-metallic Anti-friction Runners	Advanced Products & Sys.
			Cascade
			Calpico
			Pipeline Seal & Insulator
			Powerseal
			Raychem
2-3	Chlorine	Sodium Hypochlorite Solution. Per City Specifications	
2-4	COATING, WATERPROOF	Epoxy Resin Based Cementitious Trowel Grade protective, waterproofing for concrete	Sika Top Seal 107
			STO CR 241
2-6	COUPLING, TRANSITION FLEXIBLE	4" and Larger Steel or Ductile Iron Construction, Slip x Slip, Epoxy Coated with 304 or 316 Stainless Steel Bolts and Nuts. For use on AC, PVC, DI, or Steel Pipe. Proper coupling shall be used for each type pipe	Ford FC1, FC2A, FC2W
			Romac 501, XR 501, Macro HP
			JCM 215 Long DI Coupling Cat. No. 215-0905
			Smith-Blair 441-442, 461
			JCM 210 DI Coupling
2-7	COUPLING, TRANSITION RESTRAINED	For use on AC, PVC, DI, or Steel Pipe, Contractor shall be responsible for providing the proper couplings for each type of connection	EBAA Inc. Series 3800
			Smith-Blair 473
			JCM 241 or 242 with JCM 630 AC Pipe
2-8	FLANGED COUPLING, ADAPTERS RESTRAINED		EBAA Inc. Series 2100
			Romac RFCA for PVC Pipe
			Star-Products Pipe Restrainers Series 1100
2-9	FITTING, PIPE RESTRAINT	Mechanical Joint and Pushout Joint Restraint AWWA PVC and Ductile Iron Pipe	EBAA Inc. Series 1100 (Ductile Iron)
			Field Lok Gaskets
2-10	BEND, BURY, DUCTILE IRON	6" Ductile Iron Bury Bends, Long Radius, Flg x MJ/PO (Use of Short Radius Bury Bends with City Engineer Approval Only)	Star
			Sigma
			Tyler
			Clow
			South Bay Foundry
2-15	EPOXY ADHESIVE	High-Modulus, Low Viscosity, Epoxy Resin Based Adhesive suitable for Grouting Bolts or Dowels	Sika Sikadur 31
			Sika Sikadur 35
3-1	FIRE HYDRANT	6" Standard 150 PSI Wet Barrel Ductile Iron Fire	Clow 2050, Clow 2065

CITY OF EL SEGUNDO APPROVED MATERIALS LIST FOR  
USE ON CONSTRUCTION OF POTABLE WATER FACILITIES

NO.	ITEM	DESCRIPTION	MANUFACTURER/MODEL
3-2	Fire Hydrant Check Valve	Fire Hydrant Check Valve	Clow LBI 400A or Mueller J6000
3-3	FIRE HYDRANT, 200 PSI or Higher	Project Specification Submittal Required	
3-4	FITTING, DUCTILE IRON	Flanged, Mechanical, Joint or Push-on Tees, Bends, Crosses, Reducers, Adapters, etc., for Water Lines 4" and larger. Manufactured per AWWA C110 and C153. Double Cement Mortar Lined.	Griffin Nappco/Sigma Star Tyler
<b>3-7 Not Used</b>			
			US Pipe Full Face Flange-Tyte Gasket Calpico

CITY OF EL SEGUNDO APPROVED MATERIALS LIST FOR  
USE ON CONSTRUCTION OF POTABLE WATER FACILITIES

NO.	ITEM	DESCRIPTION	MANUFACTURER/MODEL
3-6	GASKET	1/8" Thick Full Face or Ring, Aramid Fiber Bound with Nitrile. No Asbestos Content (KEEP NSF 61 approved gaskets)	Garlock 3000
			Johns-Manville
			Klinger 4401
			PSI NSF Approved
			Tripac 2000
			Tripac 5000
3-7	GASKET, JOINT RESTRAINT	Rubber Ring Type with Stainless Steel Locking Segments Vulcanized into the Gasket. For use on PVC Carrier and Casing Pipes.	JM Clipper Gaskets 660 and 880
			US Pipe Flange-Tyte Gasket
3-8	GASKET, RUBBER RING	3mm (1/8") Thick, Rubber Ring Type, 1.72 Mpa (250 PSI) Maximum. For 100mm (4") through 900mm (36" Pipe Flanges	Calpico Johns-Manville US Pipe
3-9	GREASE	For Bolt Corrosion Protection on Buried Bolts, NO-OX-ID Type	Sanchem NO-OX-ID Dearborn Chemical
3-12	JOINT SEALING COMPOUND, PLASTIC ROPE	For use on Pre-cast Vault and Manhole in Grooved Joints between sections	Quickset Joint Sealing Compound
3-10	LUBRICANT, PIPE GASKET	Rubber Gasket Pipe Lubricant for use on PVC or ductile Iron Pipe Joints, NSF Listing required.	Whitlam Blue Lube Phoenix
3-11	METER	Supplied by Contractor	Per City Specification. Metron Farnier
4-1	METER BOX AND LID	1" Meter or smaller - Meter Box - 15-1/4" x 22" x 11-3/4" (Incidental/Alley)	Brooks 37MB J&R Concrete Products: No.W4-1/2
4-2	METER BOX AND LID	1-1/2" to 2" Meter - Meter Box - 18-3/4" x 30-3/8" x 13-1/2" (Incidental/Alley)	Brooks 38MB J&R Concrete Products: No.W5-1/4 DFW: DFW65CH4-14-4
4-3	METER BOX AND LID	To Be Used With Manifold Type Meter Installations - Meter Box - 15-3/16" x 37" x 12-3/4" (Incidental/Alley)	DFW: DFW1730FH4-12-4
4-4	PAINT	Valve Box Lids Prime Coat required on all above ground metal surfaces	Sinclair Gloss Enamel Blue
4-5	PAINT	Fire Hydrants Prime Coat required on all above ground metal surfaces	Yellow (2 coats)
4-7	PAINT	Backflow Assys & Vent Pipes, Meters, Regulators, Vault Piping, Air Vaives. Prime Coat required on all above ground metal surfaces (use Thnemec	Sinclair Gloss Enamel Blue
4-8	PIPE, COPPER TUBING	1" Type K Soft Seamless rolled Tubing 2" Type K Soft Seamless Straight Lengths 1" and 2" Type K Rigid Seamless Straight Lengths	Cerro
			Halstead
			Lee
			Mueller Phelps-Dodge
4-9	PIPE, DUCTILE IRON	For Water Lines 100mm (4") and larger manufactured per AWWA C111 C115, C150, C151. Double Cement Mortar Lined	American Pipe
			Griffin
			Pacific States
			U.S. Pipe
5-1	PLASTIC ENCASEMENT	8-mil Thick Polyethylene Encasement Sleeve for Ductile Iron Pipe (DIP) per AWWA C105 and Recycled PVC, CMC/L, or DIP Non-Purple Water Pipe. Clear Sleeve for Potable Water	Northtown-Polywrap
			8-mil Thick Polyethylene Encasement for Buried

CITY OF EL SEGUNDO APPROVED MATERIALS LIST FOR  
USE ON CONSTRUCTION OF POTABLE WATER FACILITIES

NO.	ITEM	DESCRIPTION	MANUFACTURER/MODEL
5-2	PLASTIC WRAP	Fittings and Valves -- Double Wrap Clear Sleeve for Potable Water	Northtown-Polywrap
5-3	Service Piping Wrap	Polywrap for service lateral piping	Northtown Polywrap - C
5-4	PRIMER, WAX TAPE	Surface Primer for Underground Application of Petrolatum Wax Tape	Carboline Denso Paste
			Trenton Tem-Coat

CITY OF EL SEGUNDO APPROVED MATERIALS LIST FOR  
USE ON CONSTRUCTION OF POTABLE WATER FACILITIES

NO.	ITEM	DESCRIPTION	MANUFACTURER/MODEL
5-5	SERVICE SADDLE FOR ACP AND DI PIPE	Cast Brass ASTM B62 Body with Silicone Bronze Double Straps, IP Outlet Sizes 25mm (1") and 50mm (2"). <b>Ball Corp. and Saddle shall be constructed by same manufacturer.</b>	Jones J-979
			Smith-Blair 323
			Romac 202B
			Mueller BR2B
5-11	TAG, BRASS IDENTIFICATION	1" Diameter, 18 Gauge Brass with 3/16" Die Stamped Letters and Numbers, Suitable for Attachment to Cathodic Protection Wires by means of a Nylon Zip Tie.	Ford 202BS
			Jones J-969
			Romac 202N
5-6	TAPE, OUTER WRAP	Adhesive Plastic Outer Wrap for Wax Petrolatum Tape in Underground Applications	Polyken 960
			Trenton Polyply
5-7	TAPE, UTILITY	10 to 50 Mil x 2" Wide General Utility Tape for Corrosion Protection of Above and Below Ground Pipes	Calpico
			3M 50, 51
6-1	TAPE, WARNING/ IDENTIFICATION	6" Wide, Warning/Identification (Non-Metallic) Marking Tape for Buried Facilities with Continuous Warning "Caution Water Main Buried Below" or "Caution Treated Urban Run-Off Water Buried Below" Tape for Recycled Water shall be Yellow with Black Lettering	Calpico, Type 1
			Line-Tec, Type B
			T.Christy Eng., Type 1
			Terra Tape, Standard 250
			Thor, Elast Tec
2	TAPE WARNING/ IDENTIFICATION FOR RECYCLED IRRIGATION	3" Wide, Warning/Identification (Non-Metallic) Marking Tape for Buried Irrigation Pipelines. Purple Color with Continuous warning Caution Reclaimed Water Main Buried Below"	Calpico, Type 1
			Line-Tec, Type B
			T.Christy Eng., Type 1
			Terra Tape, Standard 250
			Thor, Elast Tec
6-6	VALVE STEM EXTENSION SS	Round or Square 1-1/2" Diameter SS Rod, Welded Construction, with Top Centering Ring and AWWA 2" Operating Nuts Top and bottom. Use when extension longer than 8 foot.	Northtown
			Pipeline Products SX-908
6-7	VALVE, BALL WITH LOCKING TABS	3/4" Bronze, Straight, FIP x FIP with Locking Tabs and Handle	Ford B11-233WW-NL
			Jones J-1900W
			3/4" Mueller B 20200N
			AY McDonald 76101W
6-8	VALVE, BUTTERFLY 150 PSI	18" and Larger, AWWA C504, Class B. Thermosetting or Fusion Bonded Epoxy coated and Lined. Class D or E Flange x Flange Ends	M&H 1450, 4500

CITY OF EL SEGUNDO APPROVED MATERIALS LIST FOR  
USE ON CONSTRUCTION OF POTABLE WATER FACILITIES

NO.	ITEM	DESCRIPTION	MANUFACTURER/MODEL
			Mueller Lineseal III
			Pratt Groundhog
6-9	VALVE, BUTTERFLY 250 PSI	18" and Larger, AWWA C504, Class B. Thermosetting or Fusion Bonded Epoxy coated and Lined. Class D or E Flange x Flange Ends 4" through 12", non-rising Low Zinc Bronze	M&H 1450, 4500 (Class 250) Mueller Lineseal XP 250 Pratt Triton HP-250
6-10	VALVE, GATE, RESILIENT WEDGE (RWGV)	Stem, Ductile Body and Bonnet, encapsulated Wedge per AWWA C509 Epoxy Coated Interior. Valves larger than 12" shall be manufactured to AWWA C515, with 250 PSI Rating	Mueller 2362 (AWWA C509), Mueller 2361 (AWWA C515) Clow Kennedy
7-1	VALVE BOX	For Gate Valves & Butterfly Valves, See Standard Dwg W13, Lids shall be marked "Water"	G05T Traffic Box 10-3/8" I.D. x 12" by Christy/Oldcastle
7-2	VALVE BOX	Normally Close Valve, Lids shall be marked "Water"	G05T Traffic Box 10-3/8" I.D. x 12" by Christy/Oldcastle
7-3	VALVE BOX	1" Blow Off or Manual Air Releases. See Standard Dwg W5, Lids shall be marked "Water"	G05T Traffic Box 10-3/8" I.D. x 12" by Christy/Oldcastle
7-4	VALVE BOX	2" Blow Off or Manual Air Release. See Standard Dwg W6 Lids shall be marked "Water"	G05T Traffic Box 10-3/8" I.D. x 12" by Christy/Oldcastle
7-5	VALVE BOX	4" Blow Off Assembly.	G05T Traffic Box 10-3/8" I.D. x 12" by Christy/Oldcastle
7-6	Valve Box Can Extensions		Tyler Union RK Industries
7-7	Valve Can Cover		Sigma-VB-4884-C114A08B01
7-8	WIRE, TRACER	#14 AWG Solid Copper Wire, with Cross Linked Polyethylene insulation. White or Yellow in Color	Baron Cosberg Industries Paige Northtown Regency Wire Christy
7-9	WIRE, TRACER CONNECTOR	Direct Bury Silicone-Filled Capsule Tube with Standard Wire Nut or Silicone-Filled Wire Nut Connectors for Tracer Wire Connections.	3M DBR-6 King 4 King 5 King 6

**180607 - CITY OF EL SEGUNDO WATER STANDARD DETAILS**

El Segundo Water Details			
	Detail No.	Sheet No.	Sheet Title
1	WT-1	1 of 1	1-inch & 2-inch Copper Branch Service
2	WT-2	1 of 1	Fire Hydrant Assembly
3	WT-3	1 of 2	2-inch Copper Fire Line
4	WT-3	2 of 1	New Fire Service Installation
5	WT-4	1 of 1	New 3"-8" Water Service Installation With Backflow Preventer
6	WT-5	1 of 1	Thrust and Anchor Block Tables
7	WT-6	1 of 2	Restrained Length Tables Horizontal
8	WT-6	2 of 2	Restrained Length Tables Vertical
9	WT-7	1 of 1	Water Main Trench Detail
10	WT-8	1 of 1	Pipe Casing Installation
11	WT-9	1 of 1	Fire Hydrant, Valve and Tee Removal Detail
12	WT-10	1 of 2	New Gate Valve Installation
13	WT-10	2 of 2	Adjustable Valve Box with Cap in AC Pavement
14	WT-11	1 of 1	1-inch or 2-inch Air and Vacuum Release
15	WT-12	1 of 3	To be Used For: 3/4-inch & 1-inch Meters
16	WT-12	2 of 3	To be Used For: 1-1/2-inch & 2-inch Meters
17	WT-12	3 of 3	To be Used With Manifold Type Meter Installations
18	WT-13	1 of 3	5/8" x 3/4" & 1" Water Meters
19	WT-13	2 of 3	1.5" & 2" Water Meters
20	WT-13	3 of 3	3" Water Meter







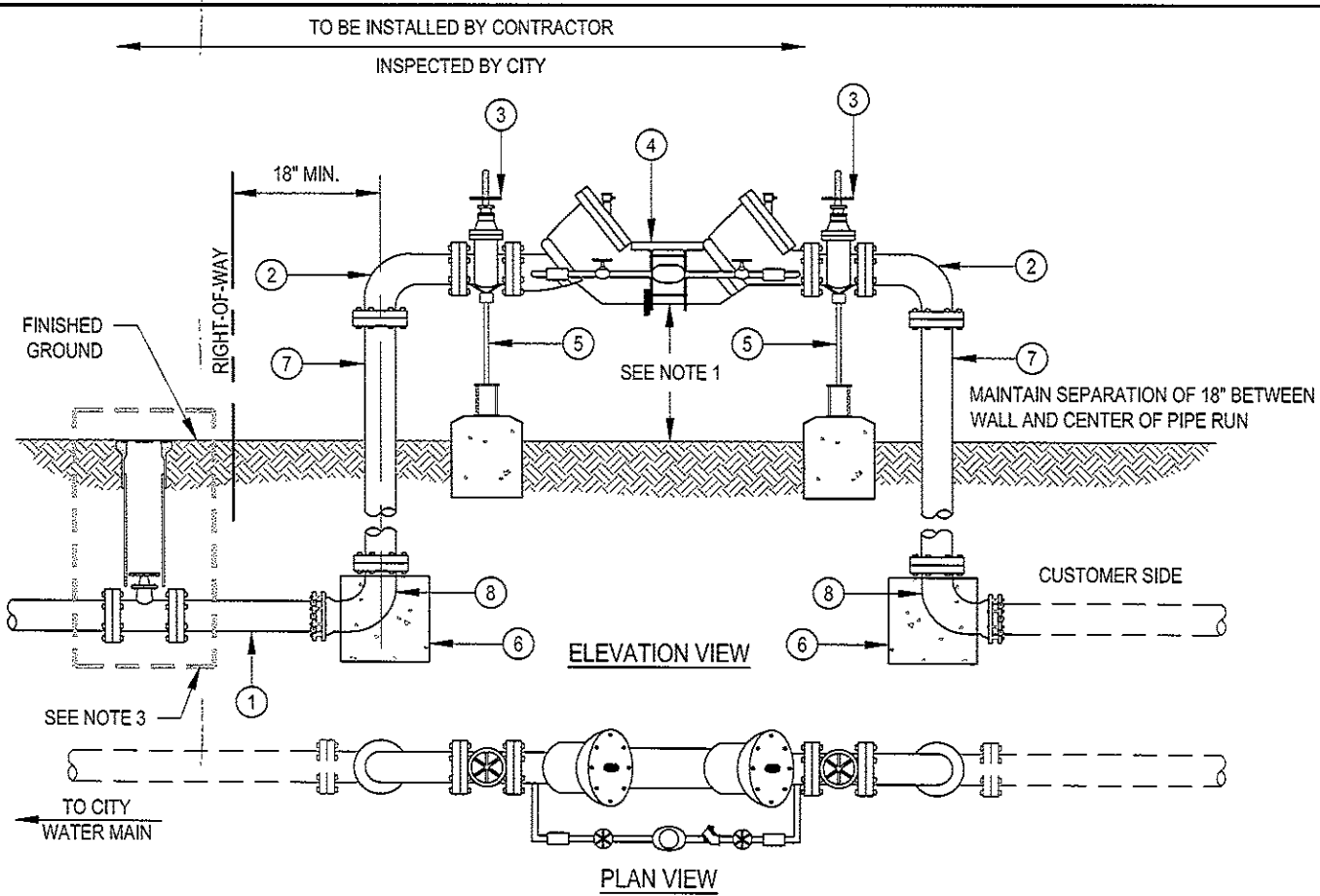

**NOTES:**

1. WATER SERVICE SHALL BE INSTALLED WITH 12" MINIMUM TO 30" MAXIMUM CLEARANCE ABOVE NATURAL FINISHED GRADE AND SHALL BE READILY ACCESSIBLE FOR INLINE SERVICE AND TEST (REF. TO L.A. COUNTY DHS, SAFE PLUMBING PRACTICES).
2. THE APPROVED BACKFLOW PREVENTION ASSEMBLY SHALL BE FURNISHED BY THE MANUFACTURE AS A COMPLETE ASSEMBLY, METER TO BE FURNISHED BY THE CONTRACTOR (MEASURED IN CU. FT.).
3. FOR 2 INCH SERVICE INSTALLATIONS, SEE DETAIL WT-3 (SHEET 1/2).
4. DCDA MUST BE INSTALLED AS CLOSE AS PRACTICAL TO THE PROPERTY LINE AND COMPLETELY WITHIN PRIVATE PROPERTY.

\* PROPERTIES WITH ONSITE AUXILIARY WATER SUPPLIES OR CHEMICAL INJECTION FIRE SYSTEMS MAY REQUIRE A REDUCED PRESSURE PRINCIPLE BACKFLOW PREVENTION ASSEMBLY. CONTACT THE EL SEGUNDO WATER DEPARTMENT PERSONNEL TO CONSULT AND CONFIRM THE REQUIRED BACKFLOW PREVENTION ASSEMBLY REQUIRED.

ITEM	MATERIAL
①	DUCTILE IRON PIPE CL350, TYPICAL
②	90° BEND (FLG x FLG)
③	OS & Y GATE VALVE (FLG x FLG)
④	USC APPROVED BACKFLOW PREVENTION ASSEMBLY - DOUBLE CHECK DETECTOR ASSEMBLY*
⑤	ADJUSTABLE PIPE SUPPORT
⑥	THRUST BLOCK
⑦	DUCTILE IRON SPOOL (FLG X FLG)
⑧	90° DUCTILE IRON BEND (MJ x FLG).

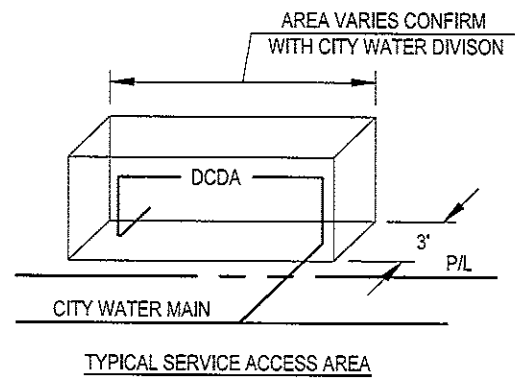

DATE	NO.	REVISION / NOTE	BY		<b>NEW FIRE SERVICE INSTALLATION</b>
APPROVED BY: _____			DATE: 20__	DES: AJS D: SEM T: C:	SCALE: NONE DATE: APP:
Water Resources Engineer					SHEET NO. 2 OF 2 <b>WT-3</b>

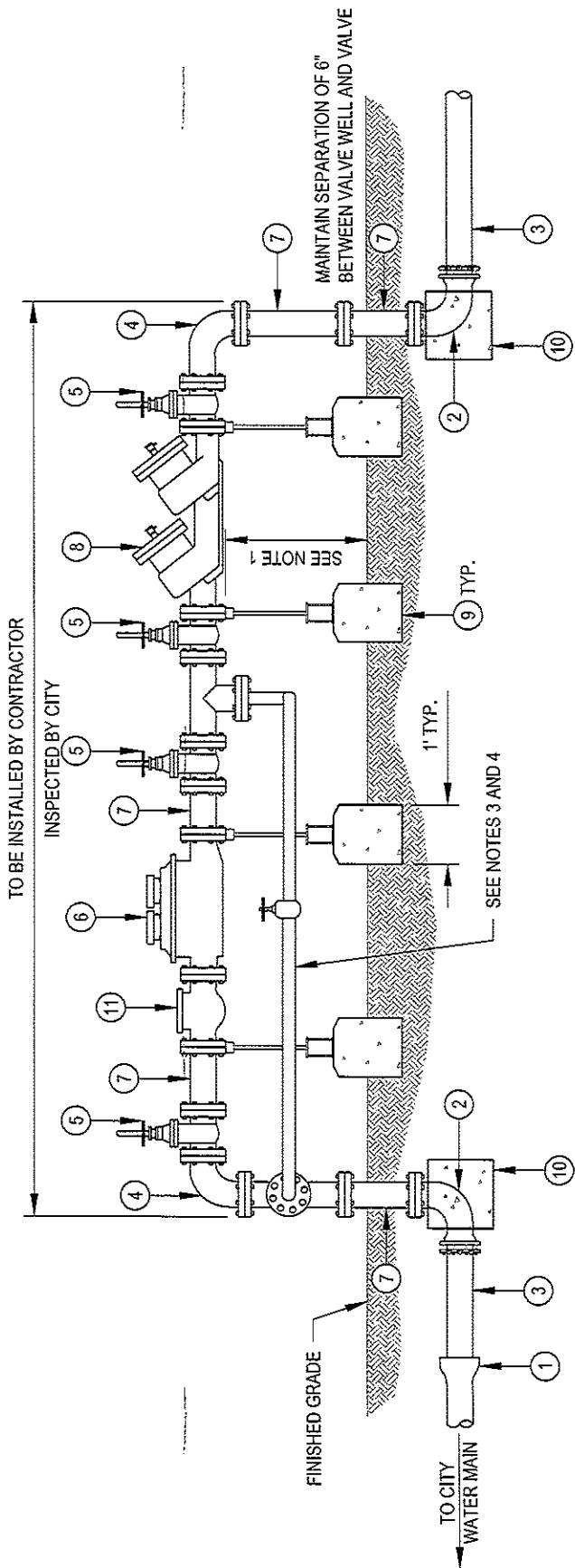

**ELEVATION VIEW**

ITEM	MATERIAL
1	BELL/SPIGOT, TYPICAL
2	90° BEND (MJ x FLG) WITH RESTRAINED MECH. JOINT
3	DUCTILE IRON, CL 350
4	90° BEND (FLG x FLG)
5	OS&Y GATE VALVE
6	METER (FURNISHED BY CONTRACTOR) (SEE SHEET WT-13)
7	DUCTILE IRON SPOOL (FLG x FLG)
8	USC APPROVED BACKFLOW PREVENTION
9	ADJUSTABLE PIPE SUPPORT WITH CONCRETE FOUNDATION
10	THRUST BLOCK
11	STRAINER (FOR 8-INCH INSTALLATION ONLY)"Strainer dependant on meter type/model"

**NOTES:**

1. WATER SERVICE SHALL BE INSTALLED WITH 12" MINIMUM TO 30" MAXIMUM CLEARANCE ABOVE NATURAL FINISHED GRADE AND SHALL BE READILY ACCESSIBLE FOR INLINE SERVICE AND TEST (REF. TO CDHS, SAFE PLUMBING PRACTICES).
2. THE APPROVED BACKFLOW PREVENTION ASSEMBLY SHALL BE FURNISHED BY THE MANUFACTURE AS A COMPLETE ASSEMBLY, METER TO BE FURNISHED BY THE CONTRACTOR (MEASURED IN CU. FEET).
3. BY-PASS LINE VARIES IN SIZE (2" TO 4")
4. BY PASS LINE MAY REQUIRE 45° BENDS OUT TO SIDE TO AVOID

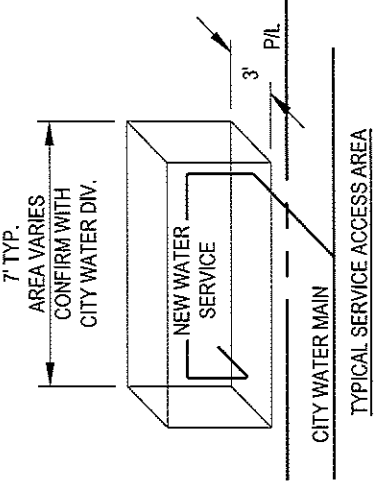

\*A REDUCED PRESSURE PRINCIPLE BACKFLOW PREVENTION ASSEMBLY WILL BE REQUIRED WHEN THE PROPERTY TO BE SERVED HAS AN AUXILIARY WATER SUPPLY AND/OR THE PROPERTY HAS A 40-FOOT VERTICAL PIPE OR 3 STORY OR HIGHER BUILDING. CONTACT THE EL SEGUNDO WATER DEPARTMENT PERSONNEL TO CONSULT AND CONFIRM THE REQUIRED BACKFLOW PREVENTION ASSEMBLY REQUIRED.

DATE	REVISION / NOTE	BY
	ORIGINAL DRAWING ISSUED	AJS

APPROVED BY: \_\_\_\_\_ DATE: 20 \_\_\_\_\_

DES: AJS  
D: SEM  
T:  
C:



**NEW 3" - 8" WATER SERVICE INSTALLATION WITH BACKFLOW PREVENTER**

SCALE: NONE  
DATE:  
APP:  
SHEET NO. 1 OF 1  
**WT-4**

TO BE INSTALLED BY CONTRACTOR

INSPECTED BY CITY

SEE NOTE 1

SEE NOTES 3 AND 4

FINISHED GRADE

TO CITY WATER MAIN

MAINTAIN SEPARATION OF 6" BETWEEN VALVE AND VALVE

7" TYP.

AREA VARIES CONFIRM WITH CITY WATER DIV.

CITY WATER MAIN

TYPICAL SERVICE ACCESS AREA

Water Resources Engineer

**TABLE 1.1 - CALCULATION ASSUMPTIONS**

CONDITION	VALUE
LAYING CONDITION	TYPE 4
SOIL CLASSIFICATION	GOOD SAND (GW)
DEPTH OF COVER	3 FEET
DESIGN/TEST PRESSURE	200 PSI <sup>1</sup>
OPERATING PRESSURE	VARIES PER PLAN
ALLOWABLE SOIL BEARING, S <sub>b</sub>	1000 PSF <sup>2</sup>
MATERIAL DENSITY, W <sub>m</sub>	150 PCF
SAFETY FACTOR	1.0 <sup>3</sup>

- 1 BEARING AREAS AND ANCHOR VOLUMES INCREASE DIRECTLY WITH INCREASED PRESSURE.
- 2 FOR SOIL BEARING VALUE OF 2000 PSF USE: 1/2 x BEARING AREA SHOWN; FOR SOIL BEARING VALUE OF 500 USE: 2 x BEARING AREA SHOWN.
- 3 CALCULATIONS BASED ON SAFETY FACTOR = 1.0. IF A DIFFERENT SAFETY FACTOR IS TO BE USED, MULTIPLY VALUES BY THAT SAFETY FACTOR.

**NOTES:**

1. ALL THRUST BLOCKS SHALL BE PORTLAND CEMENT CONCRETE MIX 560-C-3250, ATTAIN 2,000 PSI STRENGTH, AND BE PLACED AGAINST UNDISTURBED SOIL.
2. THRUST BLOCKS ON REDUCERS SHALL BE KEYPED INTO THE TRENCH BOTTOM AS SHOWN.
3. CONCRETE SHALL NOT EXTEND ONTO FLANGE OR ADJOINING PIPE.
4. DO NOT COVER FITTING BOLTS WITH CONCRETE.
5. AVOID PLACING CONCRETE ON ANY PART OF THE VALVE BONNET OR VALVE OPERATOR WHEN VALVES ARE FLANGED TO FITTINGS.
6. THE RATIO OF WIDTH (b) TO HEIGHT (h) OF THRUST BLOCK AREA SHALL NOT EXCEED 1 1/2 TO 1.
7. ALL ANCHOR RODS SHALL BE:  
FOR PIPE SIZES < 12": #4 BARS  
16": #5 BARS  
18": #6 BARS
8. COAT REBAR WITH 80 MILS OF COLD-APPLIED "NO-OX-ID" CONTACT GREASE BITUMASTIC WATER-PROOFING COMPOUND. WRAP EXTERIOR OF VALVE, ACTUATOR AND REBAR WITH 8 MIL POLYETHYLENE SHEETING AND TAPE PER IRWD SPECIFICATION.
9. MINIMUM CONCRETE COVER OVER REBAR SHALL BE 3".
10. NO CONCRETE SHALL BE POURED ON VALVE OR PIPE JOINT.
11. YIELD STRENGTH OF STEEL BARS IS ASSUMED TO BE 36 KSI.
12. ANCHOR BLOCKS SHALL BE USED AT VERTICAL BENDS WHEN PIPE IS ABOVE OR BELOW GROUND AS SHOWN ON THE PLANS.
13. IT IS THE RESPONSIBILITY OF THE CONTRACTOR TO HAVE THE SOIL BEARING CONFIRMED PRIOR TO CONSTRUCTION.
14. WHEN RESTRAINED JOINTS ARE PROVIDED FOR THE REQUIRED PIPE LENGTH, PER WT-6, THE THRUST BLOCK SIZE CAN BE REDUCED TO 25% OF ITS SIZE.

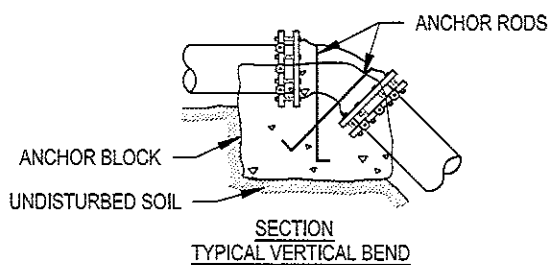
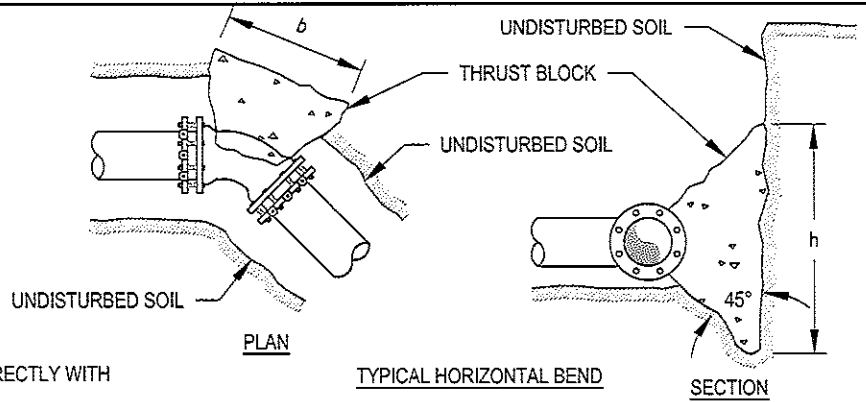

$$\text{BEARING AREA (SF)} = \frac{S_f \times T}{S_b}$$

$$\text{THRUST (LBS), } T = 2 P A \sin \frac{\theta}{2}$$

$$\text{ANCHOR VOLUME (CY)} = \left(\frac{1}{27}\right) \times \frac{S_f \times T}{W_m}$$

**TABLE 1.3 - VERTICAL ANCHOR BLOCK VOLUMES**

PIPE SIZE (IN)	22.5 BEND		45 BEND	
	THRUST (LBS)	VOLUME (CY)	THRUST (LBS)	VOLUME (CY)
4	981	0.2	1,924	0.5
6	2,206	0.5	4,328	1.1
8	3,923	1.0	7,694	1.9
10	6,129	1.5	12,022	3.0
12	8,826	2.2	17,312	4.3
16	15,690	3.9	30,777	7.6
18	19,858	4.9	38,952	9.6

**TABLE 1.2 - HORIZONTAL THRUST BLOCK BEARING AREAS**

PIPE SIZE (IN)	11.25 BEND		22.5 BEND		45 BEND		90 BEND		DEADEND / TEE	
	THRUST (LBS)	BEARING AREA (SF)	THRUST (LBS)	BEARING AREA (SF)	THRUST (LBS)	BEARING AREA (SF)	THRUST (LBS)	BEARING AREA (SF)	THRUST (LBS)	BEARING AREA (SF)
4	493	0.5	981	1.0	1,924	1.9	3,554	3.6	2,513	2.5
6	1,109	1.1	2,206	2.2	4,328	4.3	7,997	8.0	5,655	5.7
8	1,971	2.0	3,923	3.9	7,694	7.7	14,217	14.2	10,053	10.1
10	3,079	3.1	6,129	6.1	12,022	12.0	22,214	22.2	15,708	15.7
12	4,434	4.4	8,826	8.8	17,312	17.3	31,989	32.0	22,619	22.6
16	7,883	7.9	15,690	15.7	30,777	30.8	56,869	56.9	40,212	40.2
18	9,977	10.0	19,858	19.9	38,952	39.0	71,975	72.0	50,894	50.9

NOTE: IT IS THE RESPONSIBILITY OF THE CONTRACTOR TO VERIFY THE INFORMATION SHOWN HEREON PRIOR TO ITS USE.

DATE	NO.	REVISION / NOTE	BY		THRUST AND ANCHOR BLOCK TABLES
		ORIGINAL DRAWING ISSUED	AJS		
APPROVED BY:			DATE: 20	DES: AJS D: SEM T: C C: C	SCALE: NONE DATE: APP:
		Water Resources Engineer			SHEET NO. 1 OF 1 <b>WT-5</b>

**TABLE 2.1 - DEAD END, TEE, AND HORIZONTAL BENDS**

CONNECTION CONDITION	RESTRAINED LENGTH, L (FT)		
	PVC	DUCTILE IRON	POLY WARPED DUCTILE
<b>6 INCH DIAMETER</b>			
DEAD END / TEE	40	25	73
90° HORIZONTAL BEND	15	12	17
45° HORIZONTAL BEND	6	5	7
22.5° HORIZONTAL BEND	3	3	4
11.25° HORIZONTAL BEND	2	2	2
<b>8 INCH DIAMETER</b>			
DEAD END / TEE	53	33	95
90° HORIZONTAL BEND	19	16	22
45° HORIZONTAL BEND	8	7	10
22.5° HORIZONTAL BEND	4	4	5
11.25° HORIZONTAL BEND	2	2	3
<b>12 INCH DIAMETER</b>			
DEAD END / TEE	74	46	134
90° HORIZONTAL BEND	26	22	31
45° HORIZONTAL BEND	11	9	13
22.5° HORIZONTAL BEND	6	5	6
11.25° HORIZONTAL BEND	3	3	3

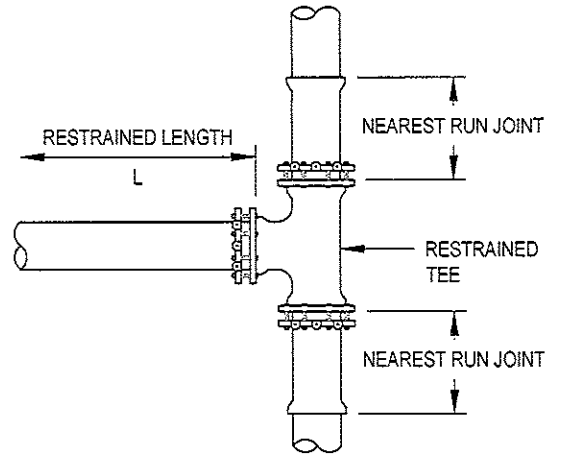

**TYPICAL TEE CONNECTION**

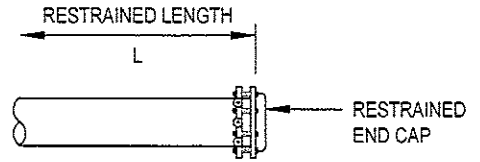

**TYPICAL DEAD END CONNECTION**

**TABLE 2.2 - CALCULATION ASSUMPTIONS**

CONDITION	VALUE
LAYING CONDITION	TYPE 4
SOIL CLASSIFICATION	GOOD SAND (GW)
DEPTH OF COVER	3 FEET
DESIGN/TEST PRESSURE	200 PSI <sup>1</sup>
OPERATING PRESSURE	VARIABLES PER PLAN
NEAREST RUN JOINT FOR TEE	1 FOOT
SAFETY FACTOR	1.0 <sup>2</sup>

- <sup>1</sup> RESTRAINED LENGTHS FOR TEES CALCULATED USING EQUAL RUN AND BRANCH DIAMETERS.
- <sup>2</sup> RESTRAINED LENGTHS CALCULATED USING SAFETY FACTOR = 1.0. WHEN A DIFFERENT SAFETY FACTOR IS TO BE USED, MULTIPLY RESTRAINED LENGTHS BY THAT SAFETY FACTOR.

NOTE: IT IS THE RESPONSIBILITY OF THE CONTRACTOR TO VERIFY THE INFORMATION SHOWN HEREON PRIOR TO ITS USE.

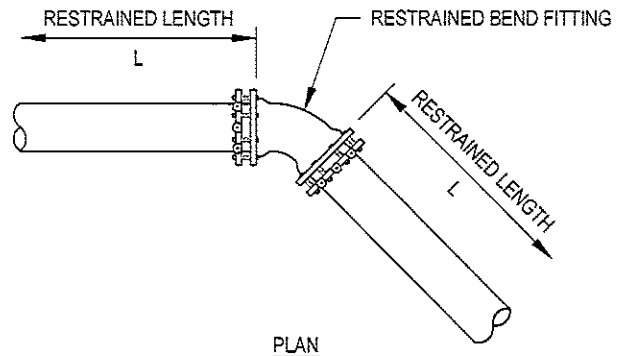

**TYPICAL HORIZONTAL BEND CONNECTION**

DATE	NO.	REVISION / NOTE	BY
		ORIGINAL DRAWING ISSUED	AJS



RESTRAINED LENGTH TABLES  
HORIZONTAL

APPROVED BY: \_\_\_\_\_ DATE: 20\_\_\_\_

Water Resources Engineer

DES: AJS  
D: SEM  
T:  
C:

SCALE: NONE

DATE:  
APP:

SHEET NO. 1 OF 2

**WT-6**

TABLE 3.1 - VERTICAL OFFSET

DEFLECTION ANGLE	VERTICAL OFFSET, H (FT)	RESTRAINED LENGTH, L1 (FT)			RESTRAINED LENGTH, L2 (FT)		
		PIPE MATERIAL*			PIPE MATERIAL*		
		A	B	C	A	B	C
6 INCH DIAMETER							
45° VERTICAL BEND	1	17	11	30	5	4	6
	2				4	3	5
	3				4	3	4
22.5° VERTICAL BEND	1	8	5	15	3	2	3
	2				2	2	3
	3				2	2	2
11.25° VERTICAL BEND	1	4	3	8	2	1	2
	2				1	1	2
	3				1	1	1

TABLE 3.1 - VERTICAL OFFSET (CONTINUED)

DEFLECTION ANGLE	VERTICAL OFFSET, H (FT)	RESTRAINED LENGTH, L1 (FT)			RESTRAINED LENGTH, L2 (FT)		
		PIPE MATERIAL*			PIPE MATERIAL*		
		A	B	C	A	B	C
8 INCH DIAMETER							
45° VERTICAL BEND	1	22	14	40	6	5	7
	2				5	4	6
	3				4	4	5
22.5° VERTICAL BEND	1	11	7	19	3	3	4
	2				3	2	3
	3				2	2	3
11.25° VERTICAL BEND	1	6	4	10	2	2	2
	2				2	1	2
	3				1	1	2
12 INCH DIAMETER							
45° VERTICAL BEND	1	31	19	56	9	7	10
	2				7	6	8
	3				6	5	7
22.5° VERTICAL BEND	1	15	10	27	4	4	5
	2				4	3	4
	3				3	3	4
11.25° VERTICAL BEND	1	8	5	14	2	2	3
	2				2	2	2
	3				2	2	2

RESTRAINED LENGTHS CALCULATED USING ASSUMPTIONS FROM TABLE 2.2 ON SHEET 1 OF SMMW-7.

\*PIPE MATERIAL :  
 A: PVC  
 B: DUCTILE IRON  
 C: POLY WRAPPED DUCTILE

NOTE: IT IS THE RESPONSIBILITY OF THE CONTRACTOR TO VERIFY THE INFORMATION SHOWN HEREON PRIOR TO ITS USE.

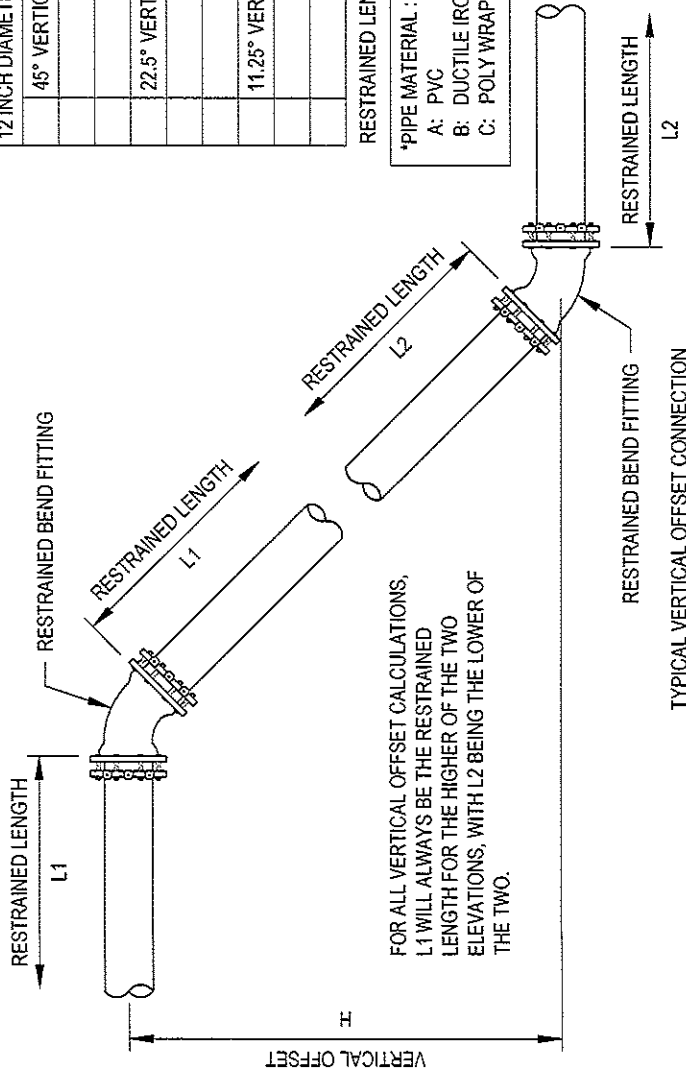

FOR ALL VERTICAL OFFSET CALCULATIONS, L1 WILL ALWAYS BE THE RESTRAINED LENGTH FOR THE HIGHER OF THE TWO ELEVATIONS, WITH L2 BEING THE LOWER OF THE TWO.



RESTRAINED LENGTH TABLES  
 VERTICAL

DES: AUS SCALE: NONE SHEET NO. 2 OF 2  
 D: DATE:  
 T: APP.  
 C: WT-6

DATE	NO.	BY	REVISION / NOTE

ORIGINAL DRAWING ISSUED  
 AUS





FOR TEE  
REMOVAL  
SEE  
BELOW

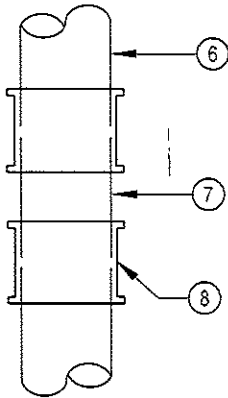
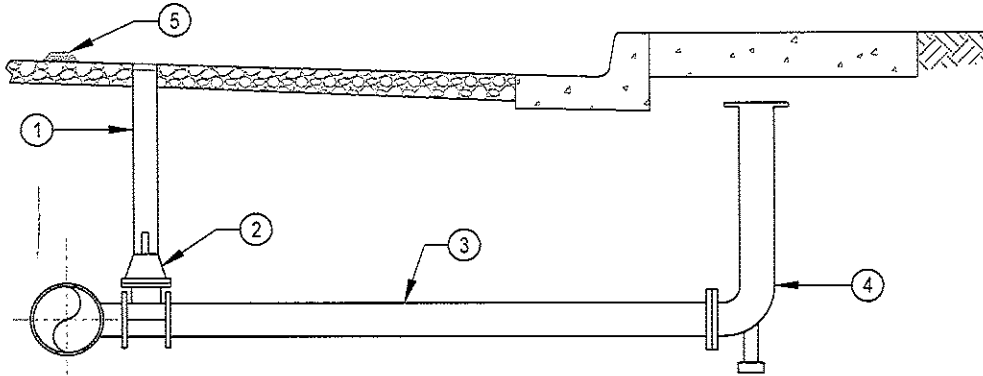

TEE REMOVAL

**NOTES:**

1. CITY ENGINEER OR FIELD INSPECTOR TO MAKE DETERMINATION OF APPROPRIATE MATERIALS TO USE AND HOW APPURTENANCES ARE ABANDONED. TEES WITH LEAD CAULKED JOINTS SHALL BE REMOVED AND REPLACED WITH LIKE SIZE D.I. PIPE.
2. IF EXISTING PIPE AND TEE ARE STEEL, USE FLEX COUPLINGS TO MAKE RE-CONNECTION.
3. IF EXISTING PIPE AND TEE ARE CAST OR DUCTILE IRON, USE EITHER A PAIR OF D.I. M.J. SLEEVES OR FLEX COUPLINGS. A BELL END OF D.I. PIPE MAY BE SUBSTITUTED FOR ONE SLEEVE OR COUPLING.
4. THIS STANDARD DRAWING MAY BE USED FOR IN-LINE VALVE REMOVAL OR OTHER IN-LINE APPURTENANCES AS DIRECTED BY ESWD
5. REPAIR OR REPLACE STREET AND SIDEWALK SURFACES PER CITY OF EL SEGUNDO PUBLIC WORKS STANDARDS. ALL TRENCHES SHALL BE BACKFILLED PER ESWD STD. DWG. WT-7.

ITEM	DESCRIPTION
①	REMOVE GATE CAN ASSEMBLY, IF PRESENT.
②	REMOVE GATE VALVE.
③	ABANDON OR REMOVE PIPE LATERAL - AS DIRECTED BY THE CITY.
④	ABANDON OR REMOVE APPURTENANCES (HYDRANT, BURY, ETC.) - AS DIRECTED BY THE CITY.
⑤	REMOVE BLUE DOT PAVEMENT MARKER(S), IF PRESENT.
⑥	PROTECT EXISTING PIPE IN PLACE, REMOVE TEE (7)
⑦	INSTALL LIKE SIZED DUCTILE IRON PIPE.
⑧	INSTALL DUCTILE IRON M.J. SLEEVE OR FLEX COUPLING - AS DIRECTED BY THE CITY. RESTRAIN WITH MEGALUG OR EQUIVALENT.

DATE	NO.	REVISION / NOTE	BY
		ORIGINAL DRAWING ISSUED	AJS



FIRE HYDRANT, VALVE AND  
TEE REMOVAL DETAIL

APPROVED BY : _____ Water Resources Engineer	DATE : 20	DES: AJS D: SEM T: C:	SCALE: NONE DATE: APP:	SHEET NO. 1 OF 1 <b>WT-9</b>
---	-----------	--------------------------------	------------------------------	---------------------------------

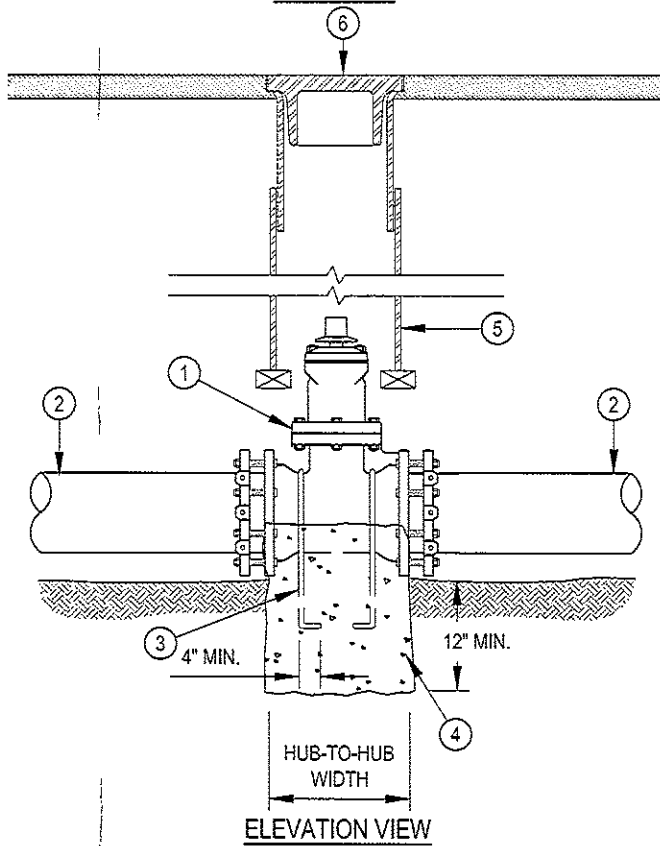
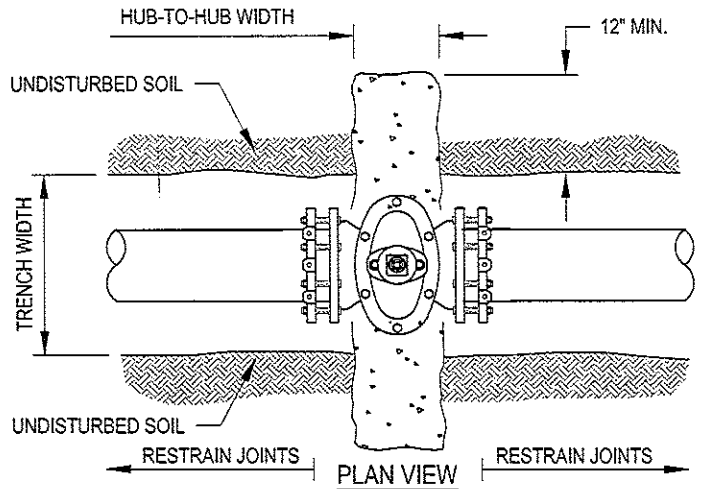

**NOTES:**

1. VALVE STEM EXTENSION NOT SHOWN.
2. VALVE ANCHOR REQUIRED ON ALL VALVES OVER 6" AND ALL VALVES AT DEAD ENDS.
3. ANCHOR STRAPS SHALL BE EMBEDDED DIRECTLY INTO THE CONCRETE THRUST BLOCK.
4. CONCRETE THRUST BLOCKS SHALL CONFORM TO STATE STANDARD 90-1.01, 470 LBS/CY CEMENTITIOUS MATERIAL (5-SACK) AND BE POURED AGAINST UNDISTURBED NATIVE SOIL.
5. ALL VALVES SHALL CONFORM TO SPECIFICATIONS FOR GATE VALVES FOR WATER WORKS SERVICE PER AWWA STANDARD 509-80.
6. 8" VALVE WELL RISER AND CAP SHALL BE USED FOR ALL GATE VALVES.

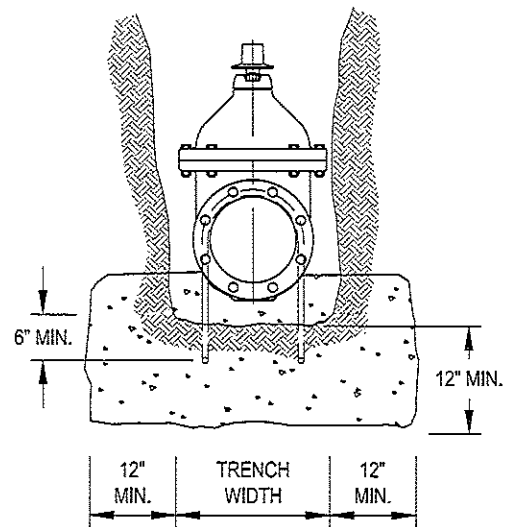

**ELEVATION VIEW**

ITEM	MATERIAL
①	DUCTILE IRON RESILIENT WEDGE GATE VALVE (MJ x MJ)
②	NEW WATER MAIN
③	ANCHOR STRAPS (REBAR NO. 4)
④	CONCRETE THRUST BLOCK
⑤	VALVE RISER. SEE SHEET WT-10 (SHEET NO. 2/2)
⑥	VALVE AND CAP. SEE SHEET WT-10 (SHEET NO. 2/2)

DATE	NO.	REVISION / NOTE	BY
		ORIGINAL DRAWING ISSUED	AJS



**NEW GATE VALVE INSTALLATION**

APPROVED BY: \_\_\_\_\_ DATE: 20\_\_\_\_  
 Water Resources Engineer

DES: AJS  
 D: SEM  
 T:  
 C:  
 SCALE: NONE  
 DATE:  
 APP:

SHEET NO. 1 OF 2

**WT-10**

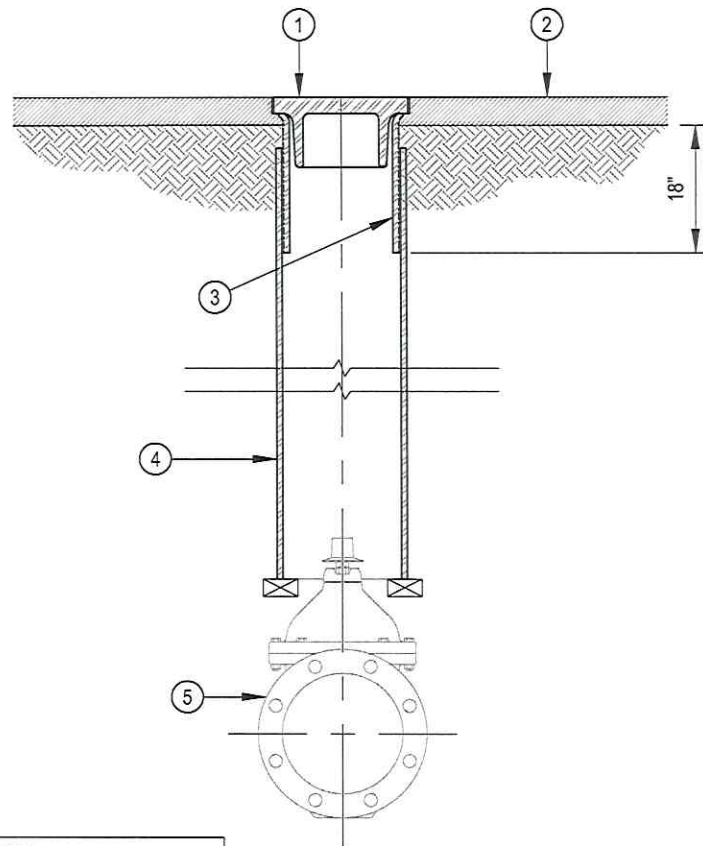
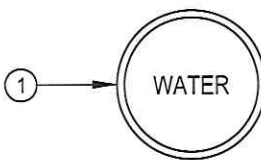

ITEM	MATERIAL
①	TRAFFIC RATED CAST IRON LID (SIGMA VB 4884, OR APPROVED EQUAL), CAST WITH THE WORD "WATER", AND PAINTED PER PAINT SCHEDULE,
②	PARKWAY GRADE OR A.C. PAVED SURFACE.*
③	ADJUSTABLE GALVANIZED VALVE CAN
④	8" DIP OR PVC EXTENSION VALVE RISER**
⑤	GATE VALVE PER WT-10 (SHEET NO. 1)

PAINT SCHEDULE	
CONDITION	COLOR
MAIN LINE VALVE CAPS	SAIL BLUE (RUST-OLEUM #7724)
FLUSHOUT, AIR RELIEF DETECTOR, CHECK, AND LARGE METER VALVE CAPS	
NORMALLY CLOSED VALVE CAPS	BLUE/RED (RUST-OLEUM #964)
ZONE VALVE CAPS	BLUE/YELLOW (RUST-OLEUM #944)
FIRE HYDRANT VALVE CAPS	
URBAN TREATED RUNOFF	PURPLE (RUST-OLEUM # )

PERMANENT PAINT No. PENDING

\* WHEN VALVE BOX IS TO BE PLACED IN A NON-PAVED AREA, CONTRACTOR SHALL CONSTRUCT A 2' x 2' x 4" A.C. PAD AROUND THE VALVE CAN.  
 \*\* EXTENSION SHALL EXTEND UP TO 3" BELOW FINISHED SURFACE.

DATE	NO.	REVISION / NOTE	BY
	-	ORIGINAL DRAWING ISSUED	AJS



ADJUSTABLE VALVE CAN WITH CAP IN AC PAVEMENT

APPROVED BY: _____	DATE: 20	DES: AJS D: SEM T: C:	SCALE: NONE	SHEET NO. 2 OF 2
Water Resources Engineer			DATE: APP:	WT-10

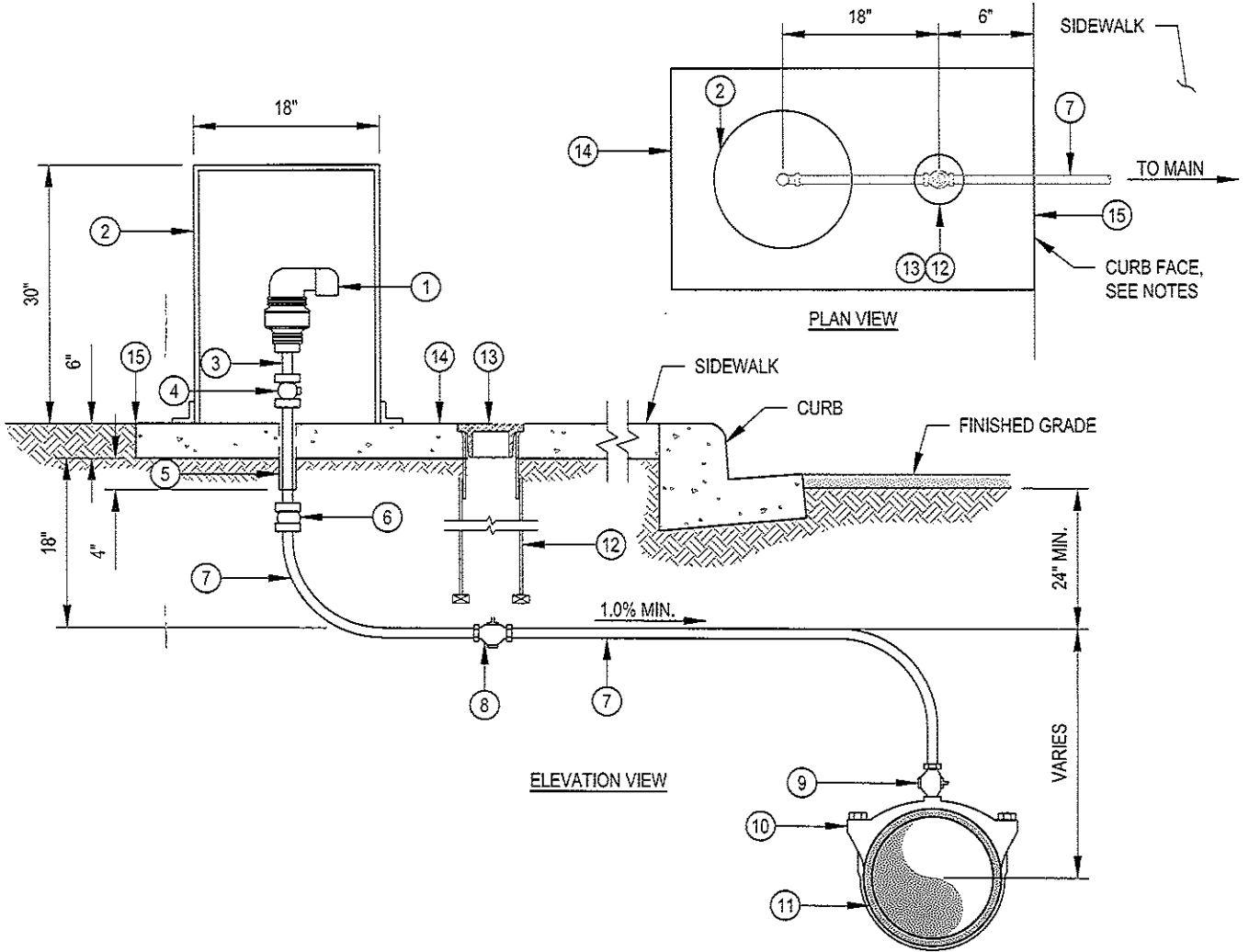

ITEM	MATERIAL
1	AIR RELEASE AND VACUUM VALVE (A.R.I.)
2	POLYETHYLENE AIR RELEASE VALVE ENCLOSURE, NOTE 1
3	2" x 1-1/2" PVC NIPPLE
4	2" BALL VALVE F.I.P.T. x F.I.P.T.
5	2" x 12" BRASS NIPPLE WITHIN 2" x 1/2" BLACK FOAM SLEEVE
6	2" BRASS COUPLING WITH SOLDER COUPLINGS
7	2" COPPER PIPE TYPE "K", SOFT, ENCASED IN POLY WRAP C
8	2" BALL VALVE WITH TEE HEAD, C x C SOLDER JOINTS OR F.I.P.T. x F.I.P.T.

ITEM	MATERIAL
9	2" BRONZE CORPORATION STOP, M.I.P.T. x COMP.
10	(SIZE) x 2" F.I.P.T SERVICE SADDLE
11	WATER MAIN
12	8" DUCTILE IRON, OR PVC, PIPE EXTENSION
13	VALVE BOX PER WT-10
14	42" x 30" x 6" THICK CONCRETE SLAB
15	COLD JOINT STRIP

**NOTES:**

- INSTALL ENCLOSURE PER MANUFACTURER RECOMMENDATIONS
- WHERE SIDEWALK EXISTS, AIR AND VACUUM VALVE ENCLOSURE TO BE PLACED AT BACK OF CURB FACE.
- IF NO SIDEWALK, AIR AND VACUUM VALVE ENCLOSURE TO BE PLACED AT 24" FROM ADJACENT PROPERTY LINE.
- ALL SERVICE LATERALS SHALL BE WRAPPED WITH POLYETHYLENE ENCASEMENT (NORTH TOWN POLY WRAP - C, OR APPROVED EQUAL).

DATE	NO.	REVISION / NOTE	BY		<b>1-INCH &amp; 2-INCH AIR AND VACUUM RELEASE</b>
		ORIGINAL DRAWING ISSUED	AJS		
APPROVED BY:		DATE: 20	DES: AJS D: SEM T: C:	SCALE: NONE	SHEET NO. 1 OF 1
Water Resources Engineer				DATE: APP:	<b>WT-11</b>





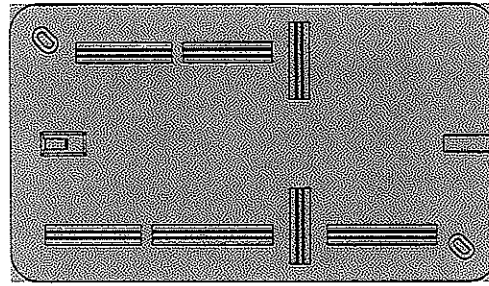
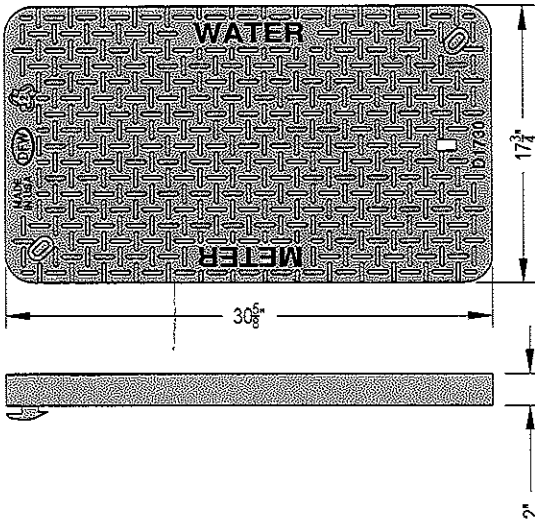

DFW1730C-4-LID

LID KEY

4 | GRAY COLOR

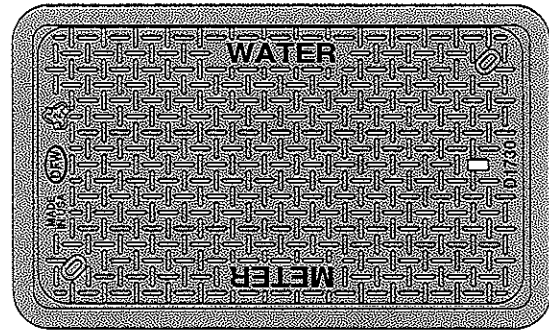
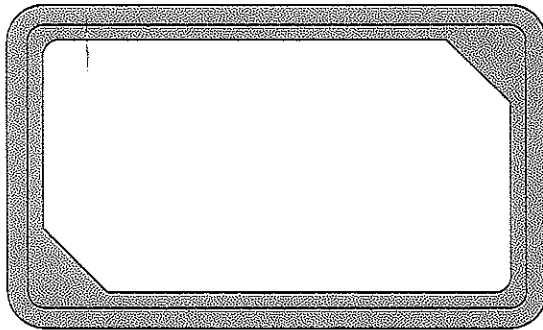

DFW1730FH4-12-4

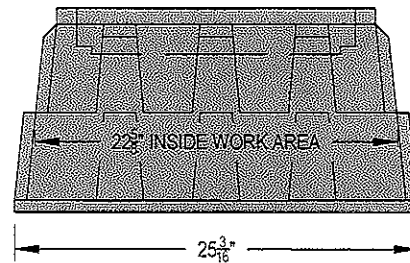
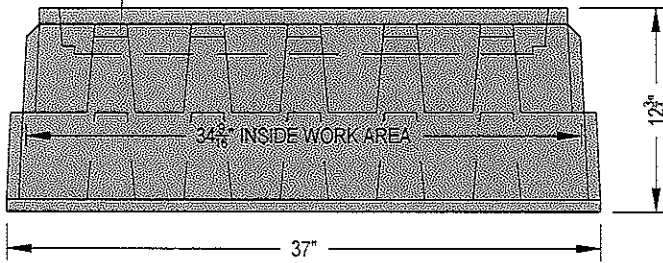

DFW1730FH4-12-BODY

NOTES

- 1) DIM'S ± 1/8" U.N.O.
- 2) LID MATERIAL: HDPE
- 3) BODY MATERIAL: LLDPE
- 4) WALL THICKNESS: 1/2" ± 5%
- 5) I.W.A. = INSIDE WORK AREA

CONFIRM METER BOX AND LID WITH  
WATER RESOURCES METER SHOP AT  
(310) 524-2745 PRIOR TO PURCHASE.

DFW PLASTICS, INC. ENGAGES IN ONGOING RESEARCH AND DEVELOPMENT TO IMPROVE AND ENHANCE ITS PRODUCTS. THEREFORE, DFW PLASTICS, INC. RESERVES THE RIGHT TO CHANGE PRODUCT OR SYSTEM SPECIFICATIONS WITHOUT NOTICE.

DATE	NO.	REVISION / NOTE	BY
		ORIGINAL DRAWING ISSUED	AJS

APPROVED BY: \_\_\_\_\_  
Water Resources Engineer

DATE: 20\_\_\_\_

DES: AJS  
D: SEM  
T:  
C:

SCALE: NONE  
DATE:  
APP:



TO BE USED WITH MANIFOLD  
TYPE METER INSTALLATIONS

SHEET NO. 3 OF 3  
**WT-12**

METRON-FARNIER SPECTRUM  
30D AND 30DB - 5/8" X 3/4"

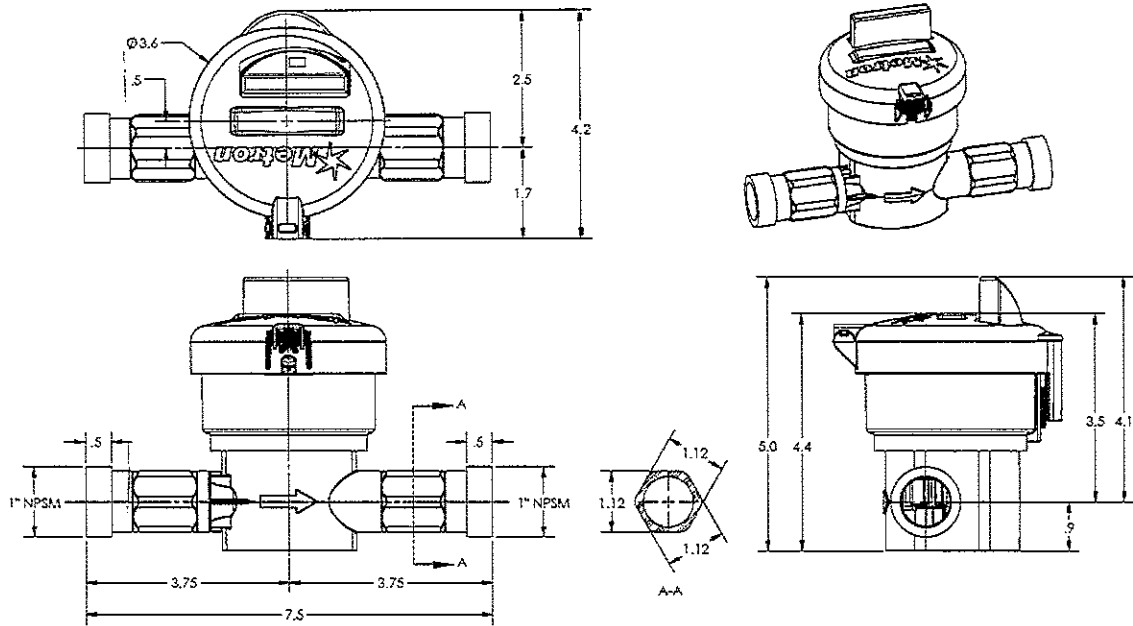

METRON-FARNIER SPECTRUM 50DL - 1"

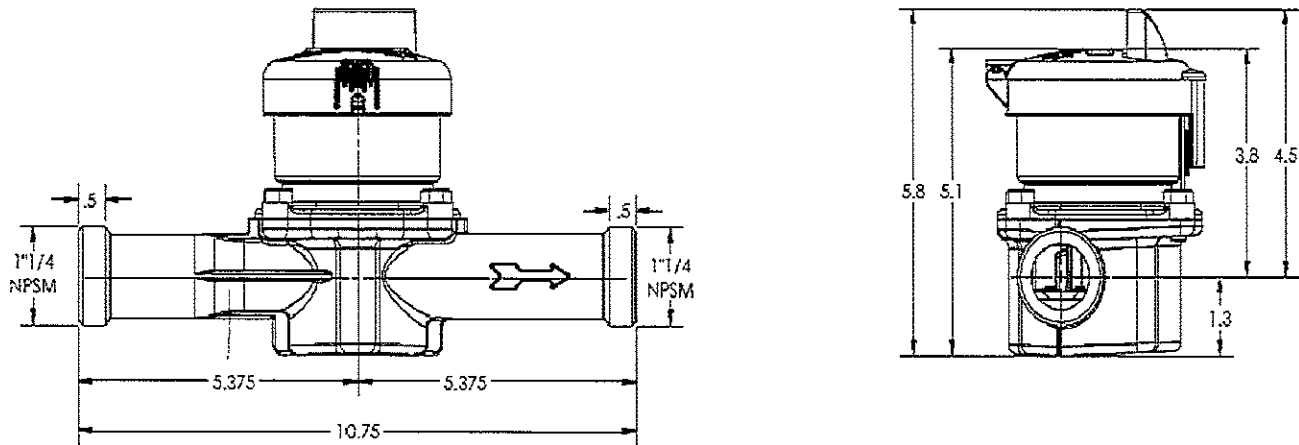

DATE	NO.	REVISION / NOTE	BY
		ORIGINAL DRAWING ISSUED	AJS



5/8"x3/4" & 1" WATER METERS

APPROVED BY: \_\_\_\_\_ DATE: 20\_\_\_\_  
Water Resources Engineer

DES: JEP  
D: TPF  
T: \_\_\_\_\_  
C: \_\_\_\_\_  
SCALE: NONE  
DATE: \_\_\_\_\_  
APP: \_\_\_\_\_

SHEET NO. 1 OF 3  
WT-13



METRON-FARNIER  
SPECTRUM 175D (3")

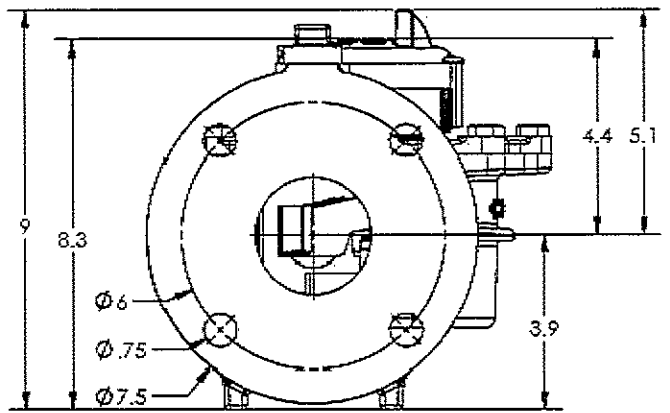
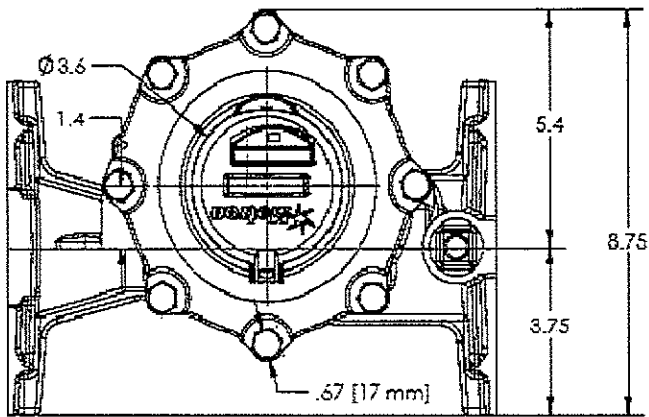
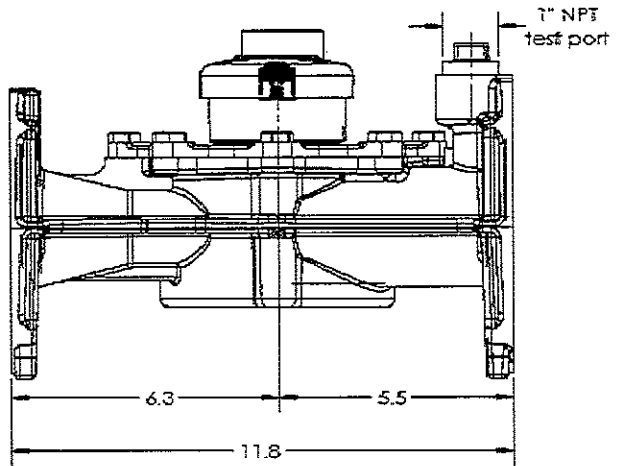
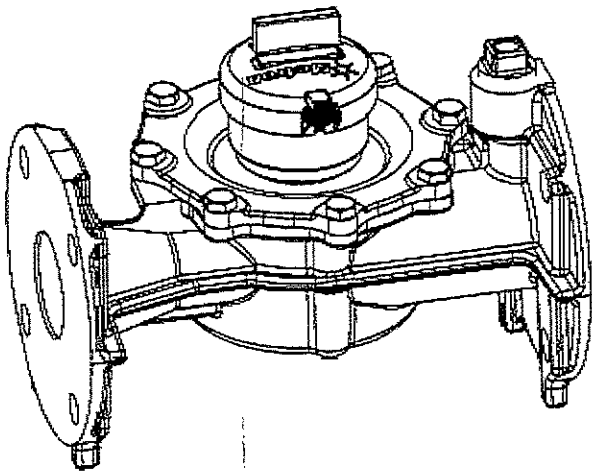

NOTES:  
ALL D MODELS HAVE INTEGRAL FLANGES AND  
OFFER MULTIPLE BRASS SPOOL/ADAPTER  
OPTIONS FOR STANDARD AWWA LAY LENGTHS.

DATE	NO.	REVISION / NOTE	BY
		ORIGINAL DRAWING ISSUED	AJS



3" WATER METERS

APPROVED BY: \_\_\_\_\_ DATE: 20  
Water Resources Engineer

DES: JEP  
D: TPF  
T:  
C:  
SCALE: NONE  
DATE:  
APP:

SHEET NO. 3 OF 3  
WT-13



Albertville Plant  
956 Industrial Blvd.  
Albertville, AL 35950

phone: 256-878-7930  
fax: 256-891-6217  
muellercompany.com

## PRODUCT SPECIFICATIONS

# JONES® J6000 SERIES WET BARREL BREAK CHECK

1. **GENERAL CLASSIFICATION – JONES J6000 SERIES BREAK CHECK:**
  - 1.1 Suitable for general waterworks service
  - 1.2 Use with wet barrel hydrants and closes with inlet pressure when hydrants are struck
  - 1.3 Features a replaceable Traffic Flange at the ground line
  - 1.4 Manufactured with ANSI/NSF 61/372 compliant components
  
2. **SELECTIVE SPECIFICATIONS (TO BE SELECTED BY CUSTOMER)**
  - 2.1 **Break Check Flange – Number of Bolts, Bolt Circle and holes size**
    - 2.1.1 **6 Bolt Inlet Connections:**
      - 2.1.1.1 9.38" (9-3/8") Bolt Circle, 0.75" (3/4") Dia.
      - 2.1.1.2 9.5" (9-1/2") Bolt Circle. 0.875" (7/8") Dia.
    - 2.1.2 **8 Bolt Inlet Connections:**
      - 2.1.2.1 9.5" (9-1/2") Bolt Circle 0.875" (7/8") Dia.
  - 2.2 **Traffic Flange – Number of Bolts, Bolt Circle and holes size**
    - 2.2.1 **6 Bolt Inlet Connections:**
      - 2.2.1.1 9.38" (9-3/8") Bolt Circle, 0.75" (3/4") Dia.
      - 2.2.1.2 9.5" (9-1/2") Bolt Circle. 0.875" (7/8") Dia.
    - 2.2.2 **8 Bolt Inlet Connections:**
      - 2.2.2.1 9.5" (9-1/2") Bolt Circle 0.875" (7/8") Dia.
  
3. **WORKING AND TEST PRESSURES**
  - 3.1 Standard working pressure is 350 psi
  - 3.2 Production testing is at twice rated pressure (700 psi)
  
4. **DESIGN FEATURES**
  - 4.1 **Overall Height – 3.75" (3-3/4")**
  - 4.2 **Light Weight – 35 Lbs., ergonomically friendly**
  - 4.3 **Heavy Duty Construction – Ductile Iron and Stainless Steel structural components**
  - 4.4 **Corrosion Resistant – Ductile Iron Body is E-Coated for long life**
  - 4.5 **Reduced Water Loss – Uses less water than other designs**
  - 4.6 **Tell-Tale Design – Mist of water clearly visible when hydrant is struck**
  - 4.7 **Safer Design – Mist less likely to cause property damage and reduces safety concerns over water column designs**
  - 4.8 **Traffic flange – breaks cleanly upon impact, yet strong enough for normal handling, shipping, and use. Permits full 360-degree rotation of hydrant to position nozzles in any desired direction**
  - 4.9 **Self-Resetting – Gravity drops Lever Arm back into place once water flow is stopped**

- 4.10 **Low Pressure Loss** – < 2.5 psi at 1,000 gpm
- 4.11 **Easy to Install** – Installs in minutes with common tools
- 4.12 **Low Maintenance** – Few moving parts and robust design
- 4.13 **Operation** – Does not affect normal hydrant use
- 4.14 **Minimizes Water Hammer** – reduces impact on infrastructure
- 4.15 **Flexible Design** – works with hydrants with an inside diameter of 6.625" (6-5/8") or less

**5 MATERIAL SPECIFICATIONS**

- 5.1 **Housing Body** – Ductile Iron, ASTM A-536
- 5.2 **Traffic Flange** – Cast Iron ASTM A-126 Class B
- 5.3 **Disc and Arm** – 304 Stainless Steel
- 5.4 **Guide Rod** – 303 Stainless Steel
- 5.5 **Gasket** – EPDM
- 5.6 **Washer** – 304 Stainless Steel
- 5.7 **NPTF Plug** – 316 Stainless Steel

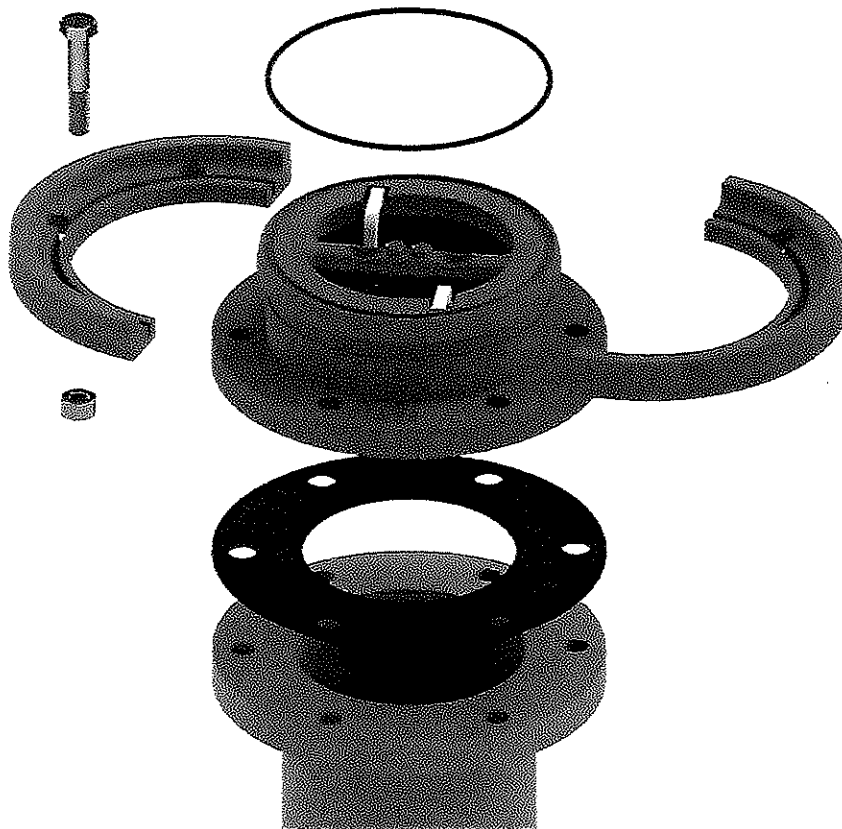

**J6000 SERIES BREAK CHECK**



WET BARREL BREAK CHECK ASSEMBLY

FLANGE X FLANGE

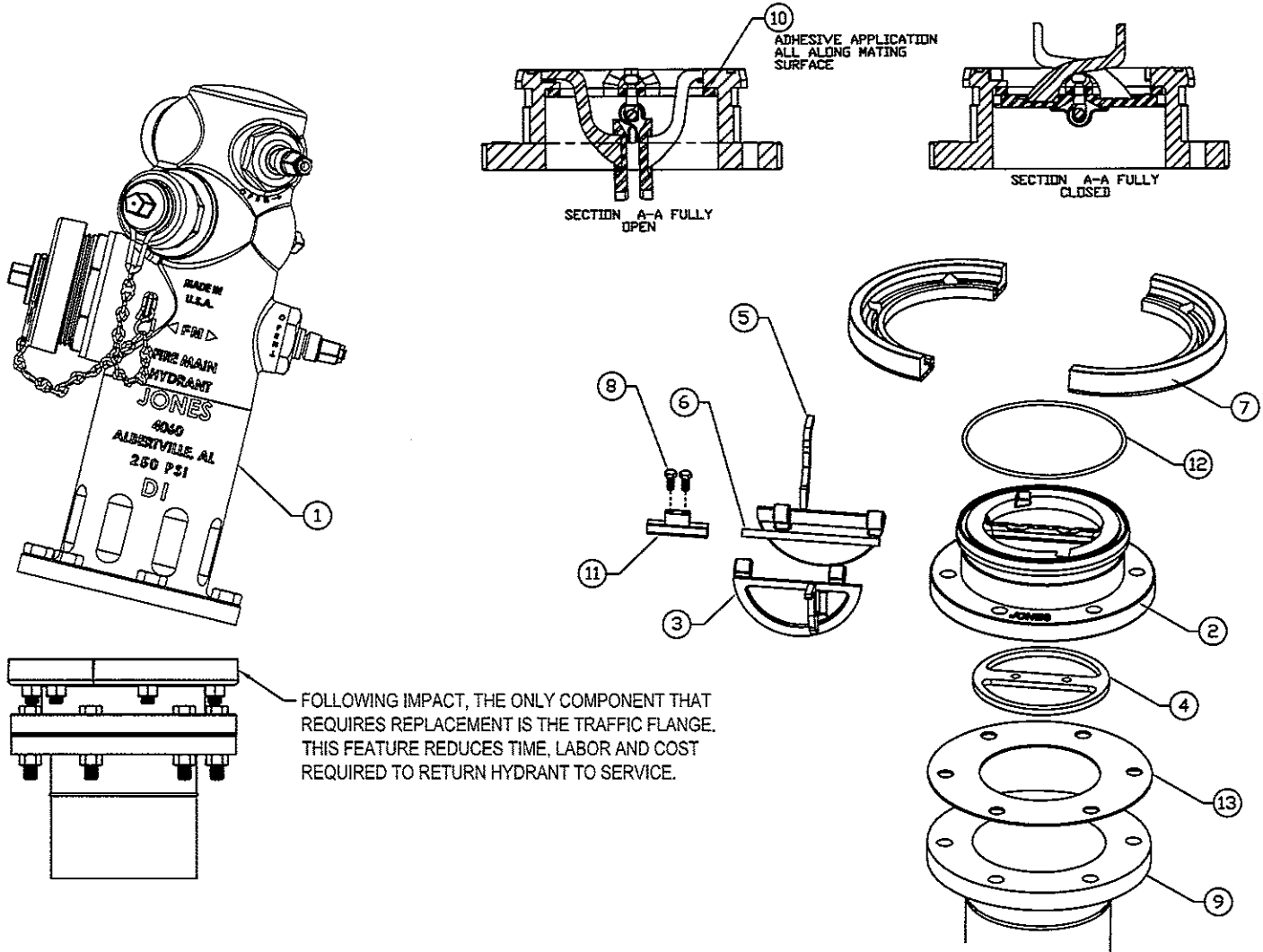

\* MANUFACTURED BY MUELLER Co. TO JAMES JONES SPECIFICATION.

FEATURES:

- \* DUCTILE IRON, CAST IRON, BRONZE AND STAINLESS STEEL CONSTRUCTION
- \* REDUCED WATER HAMMER DUE TO SLOWER CLOSING ACTION OF VALVE ATTRIBUTED TO THE "TELL TAIL" WATER STREAM PRESSURE RELIEF.
- \* EASY-TO-RESET DESIGN (NO SPRINGS)

- \* PROVIDES VISUAL TELL-TAIL WATER STREAM INDICATING HYDRANT DAMAGE
- \* AVAILABLE IN VARIOUS FLANGE BOLT HOLE PATTERNS
- \* RETURN TO SERVICE BY REPLACING SAFETY FLANGE (NO DIGGING)
- \* 250 PSI RATED (TESTED AT 500 PSI)

PARTS LIST:

ID	PART NAME	MATERIAL	ID	PART NAME	MATERIAL
1	HYDRANT	DUCTILE IRON ASTM A536 65-45-12	15		
2	BODY	DUCTILE IRON ASTM A536 65-45-12	16		
3	DISC	304L STAINLESS STEEL ASTM A351 CF3	17		
4	GASKET	EPDM ASTM 6284	18		
5	LEVER ARM	304 STAINLESS STEEL ASTM A240	19		
6	GUIDE ROD	303 STAINLESS STEEL ASTM A484 & A582	20		
7	TRAFFIC FLANGE	GRAY IRON ASTM A126 CLASS B	21		
8	5/16" - 18 BOLTS	316 STAINLESS ASME B12.2.1	22		
9	LOWER BODY	DUCTILE IRON ASTM A536	23		
10	LOCTITE 480	CYANOACRYLATE ADHESIVE	24		
11	POSITION BLOCK	304 STAINLESS STEEL	25		
12	O-RING	R34 EPDM	26		
13	FLAT GASKET	EPDM	27		
14			28		

Approvals:

Date:

LAST REVISED: 8/30/19



Albertville Plant  
956 Industrial Blvd.  
Albertville, AL 35950

phone: 256-878-7930  
fax: 256-891-6217  
muellercompany.com

## J6000 SERIES BREAK CHECK TRAFFIC FLANGE INSTRUCTION

**WARNING:** Before attempting any repairs, working on, or disassembling the Hydrant (including removing any bolts(s) holding the Hydrant together), shut off service gate valve to isolate Hydrant from main water source. **Failure to shut off gate valve to isolate Hydrant from main water source can result in serious bodily injury.**

### EQUIPMENT AND TOOLS NEEDED:

- PPE – Hard hat, safety shoes, safety vest, safety glass, work gloves
- Repair Parts – Jones Traffic Flange Kit
- Tools – Appropriate wrenches, lubricant

### REPAIR INSTRUCTIONS

1. Remove *Traffic Flange Bolts* and *Nuts* from *Hydrant* and discard.
2. Discard broken *Traffic Flange* pieces.
3. Inspect *Hydrant* and J6000 *Body* for damage; clean sealing surfaces.
4. Inspect internal components (*Lever Arm, Disc, Guide Rod and Position Block*) for damage and replace if necessary
5. Make sure *Lever Arms* are seated in J6000 *Body* pockets

### INSTALLATION INSTRUCTIONS

1. Install *O-ring* provided in the Traffic Kit in *Body* O-Ring groove
2. Place *Hydrant* on J6000 *Body*; rotate *Hydrant* to desired direction.
3. Install *Traffic Flange Bolts* in *Hydrant* Flange
4. Place *Traffic Flange halves* and thread on *Traffic Flange Nuts*.
5. Torque Nuts to 70-90 ft.-lbs.
6. Check for leaks by removing nozzle cap from top nozzle and slightly open nozzle valve. Slowly open the service gate valve. When air is evacuated from hydrant, water will come out the nozzle. Close the nozzle valve and fully open the service gate valve. Check for leaks at all joints paying close attention to repaired joints.

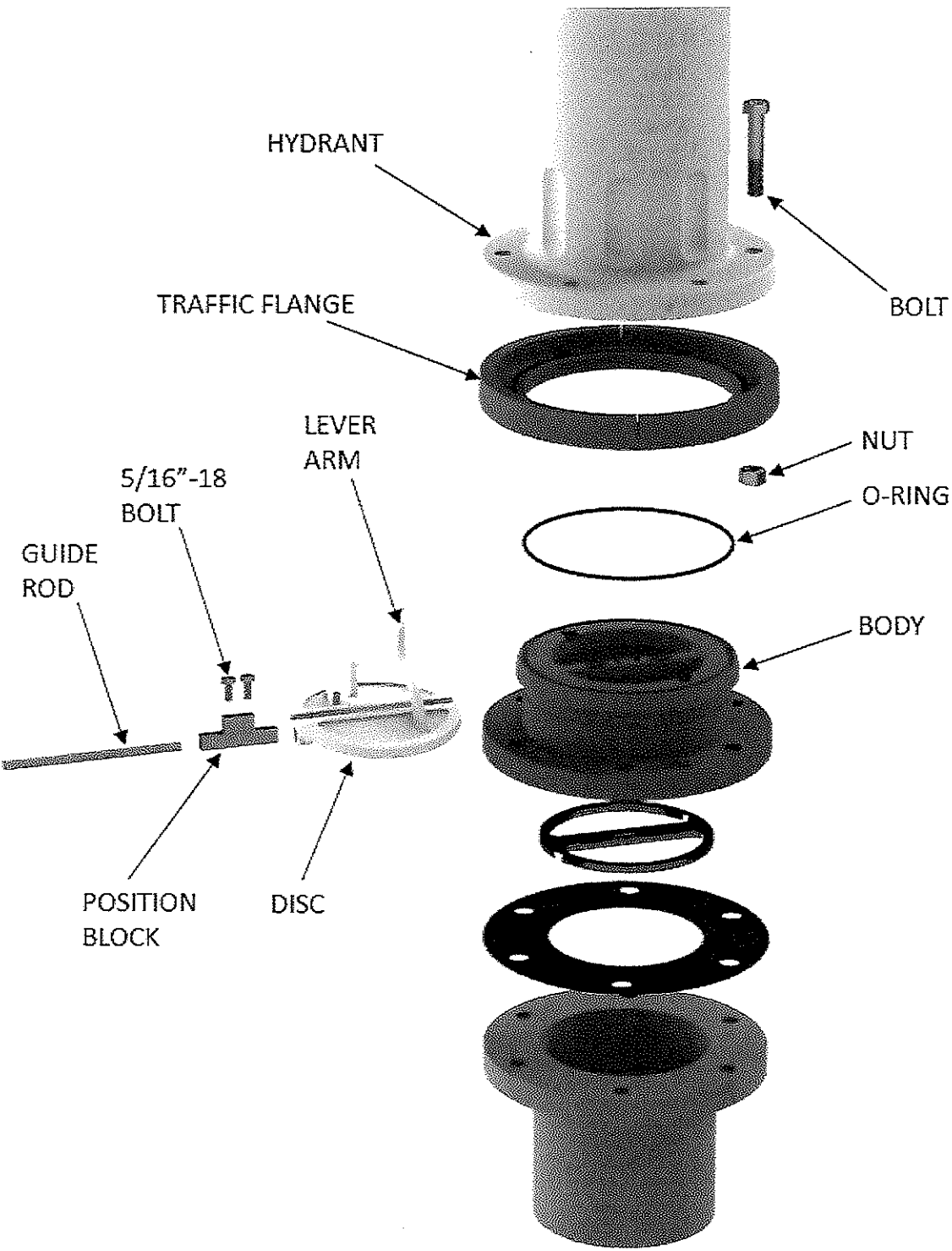

# JONES®

a MUELLER brand

## J6000 SERIES BREAK CHECK

Industry-Leading Infrastructure Protection

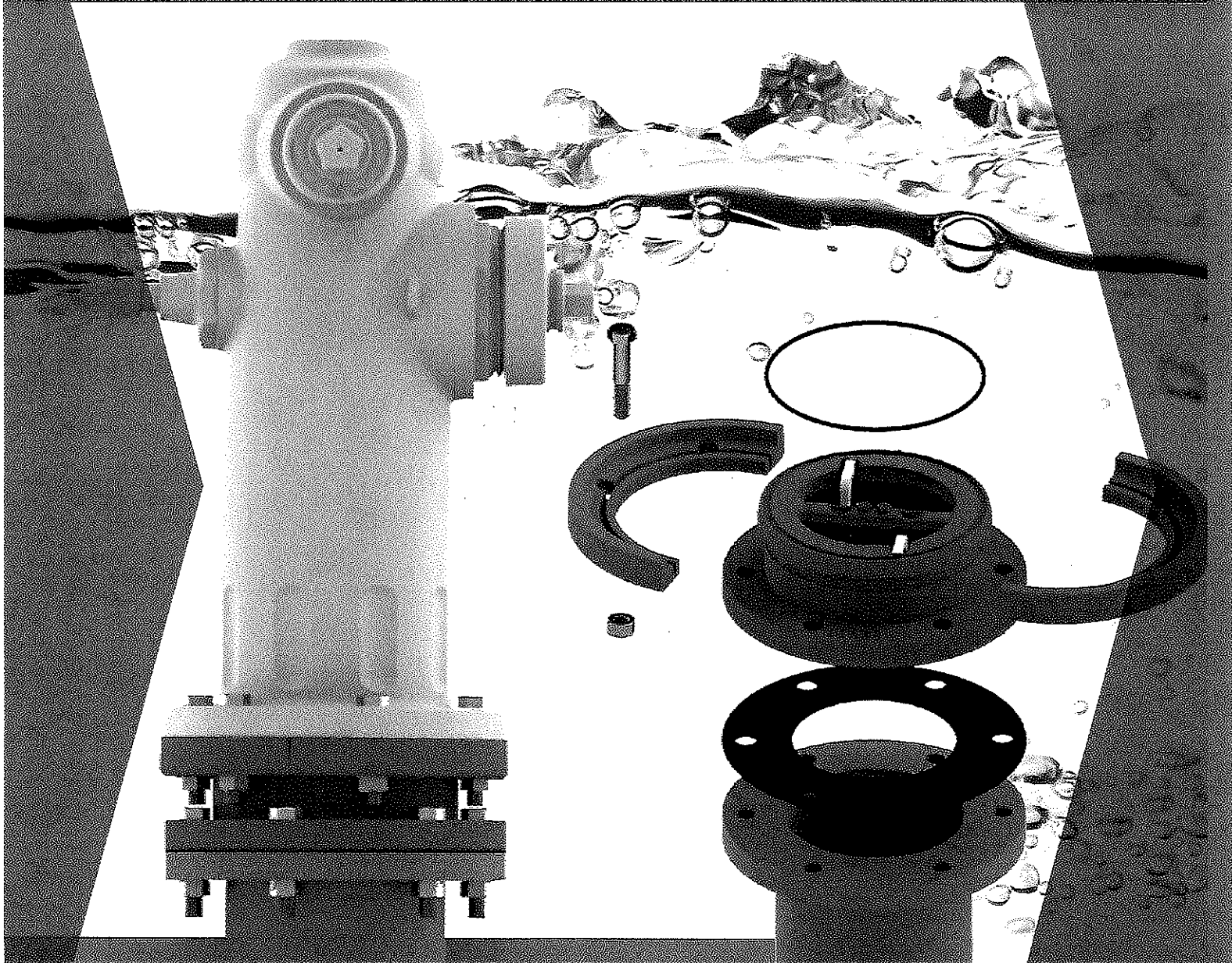

**MUELLER**

# J6000 SERIES BREAK CHECK

## Industry-Leading Infrastructure Protection

Designed for ease of installation and superior infrastructure protection, the Jones J6000 Break Check provides “install and forget” passive protection. When struck by a vehicle, the J6000 closes automatically minimizing property damage and water loss. The J6000 emits a mist of water providing notification an accident has occurred.

- ▶ 350 psi rated
- ▶ AWWA C550 compliant
- ▶ All Ductile Iron and Stainless Steel construction
- ▶ No orifices in Body, avoiding leak paths
- ▶ 360° Hydrant Rotation
- ▶ Back in service quickly after impact
- ▶ 3-3/4" Tall
- ▶ Weighs on less than 30 lbs.

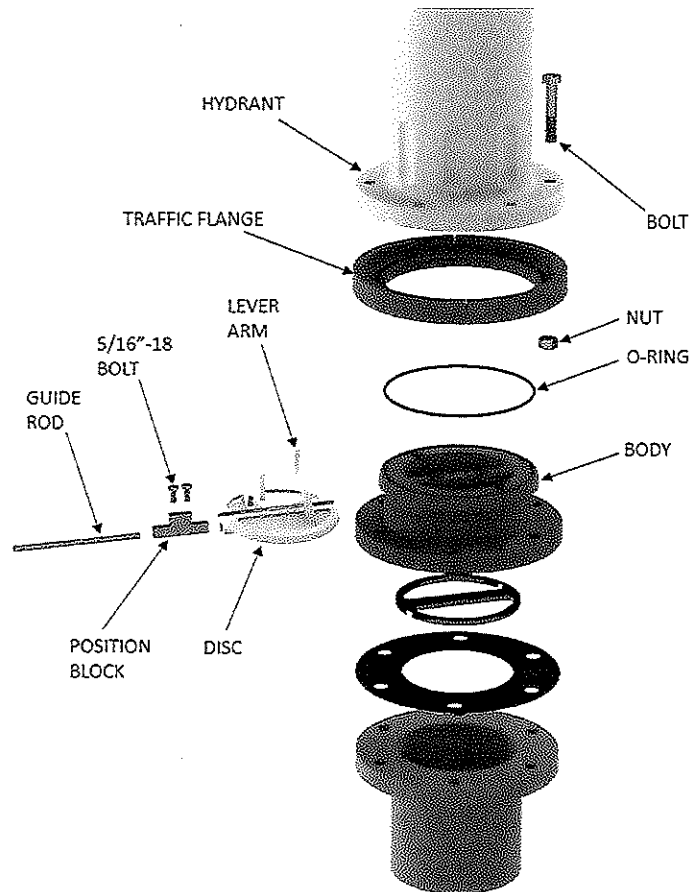
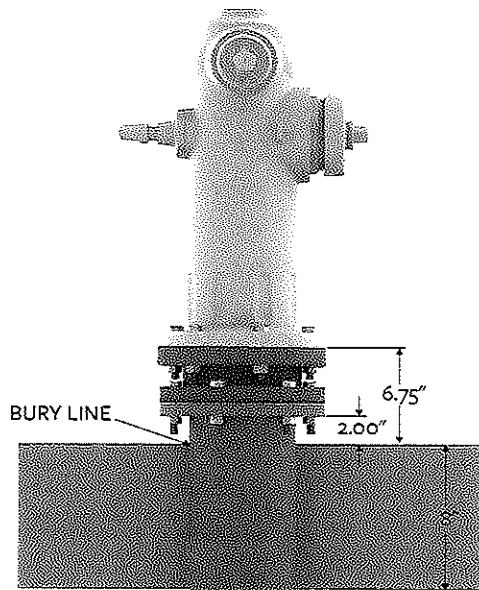

For more information about Jones water products, please visit [joneswaterproducts.com](http://joneswaterproducts.com) or call Jones customer service at 1.800.423.1323.

Mueller refers to one or more of Mueller Water Products, Inc., a Delaware corporation ("MWP"), and its subsidiaries. MWP and each of subsidiaries are legally separate and independent entities when providing products and services. MWP does not provide products or services to third parties. MWP and each of its subsidiaries are liable only for their own acts and omissions and not those of each other. MWP brands include Mueller®, Echologics®, Hydro-Gate®, Hydro-Guard®, HYMAX®, Jones®, Krausz®, Mi-Net®, Milliken®, Pratt®, Singer®, and U.S. Pipe Valve & Hydrant. Please see [www.mueller-wp.com/about](http://www.mueller-wp.com/about) to learn more.

Copyright © 2019 James Jones Company, LLC. All Rights Reserved. The trademarks, logos and service marks displayed in this document are the property of Mueller Water Products, Inc., its affiliates or other third parties. Products above marked with a section symbol (§) are subject to patents or patent applications. For details, visit [www.mwppat.com](http://www.mwppat.com). These products are intended for use in potable water applications. Please contact your Mueller Sales or Customer Service Representative concerning any other application(s).

F 14156 10/19

**MUELLER**